



HAL
open science

Performance analysis of UFMC waveform in an SOA-based analog IF over fiber fronthaul link for the C-RAN architecture

Mahdi Kasmi, Pascal Morel, Mihai Telescu, Vincent V. Choqueuse, Noël Tanguy, Stéphane Azou

► **To cite this version:**

Mahdi Kasmi, Pascal Morel, Mihai Telescu, Vincent V. Choqueuse, Noël Tanguy, et al.. Performance analysis of UFMC waveform in an SOA-based analog IF over fiber fronthaul link for the C-RAN architecture. Journée du Club Optique et Micro-Ondes (JCOM 2023), Jun 2023, online, France. hal-04149286

HAL Id: hal-04149286

<https://hal.univ-brest.fr/hal-04149286>

Submitted on 3 Jul 2023

HAL is a multi-disciplinary open access archive for the deposit and dissemination of scientific research documents, whether they are published or not. The documents may come from teaching and research institutions in France or abroad, or from public or private research centers.

L'archive ouverte pluridisciplinaire **HAL**, est destinée au dépôt et à la diffusion de documents scientifiques de niveau recherche, publiés ou non, émanant des établissements d'enseignement et de recherche français ou étrangers, des laboratoires publics ou privés.

Performance analysis of UFMC waveform in an SOA-based analog IF over fiber fronthaul link for the C-RAN architecture

Mahdi Kasmi¹, Pascal Morel¹, Mihai Telescu², Vincent Choqueuse¹, Noël Tanguy², Stéphane Azou¹

¹ENIB, Lab-STICC, CNRS, UMR 6285, CS 73862, F-29238, Brest Cedex 3, France

²Univ Brest, Lab-STICC, CNRS, UMR 6285, CS 93837, F-29238, Brest Cedex 3, France

Email: mahdi.kasmi@enib.fr

In order to provide new categories of services, there has been an evolution from fourth-generation long term evolution-advanced (4G LTE-A) to fifth-generation (5G). Thanks to its advantages, orthogonal frequency division multiplexing (OFDM) has been chosen as the modulation technique for LTE-A. However, the cyclic prefix (CP) added to each OFDM symbol deteriorates the spectral efficiency by reducing the amount of effective transmitted data. Also, the rectangular window used for pulse shaping causes a high out of band emission (OOBE), leading to the use of large guard bands. Thus, CP-OFDM is not able to respond effectively to the 5G requirements and new alternative 5G waveforms, such as universal filtered multi-carrier (UFMC), have been intensively studied. In this work, we investigate the use of the UFMC as the modulation technique in the 5G centralized radio access network (C-RAN) optical fronthaul (FH) architecture, connecting the baseband unit pool to remote radio heads, based on the analog intermediate frequency signal over fiber (AIFoF) technology. To extend the maximum reach of our system over the FH link, we use the semiconductor optical amplifier (SOA) as a booster amplifier. We consider the setup depicted in Fig.1 (a) where three CP-OFDM/UFMC bands are generated in MATLAB[®]. Each band is composed of 16 symbols with 1024 subcarriers. 330 subcarriers are modulated using 16 QAM, leading to an effective bandwidth (BW) of 400 MHz per band, and the remaining of subcarriers are nulled. For UFMC, 15 subbands composed of 22 subcarriers each are considered and filtered by a Dolph–Chebyshev filter with a length $L_f = 65$ and a side lobe attenuation of 40 dB. The filtered signals are summed up in order to obtain the resulting UFMC signal for each band. The oversampling factor is 10 and the CP length of the OFDM system is chosen to be equal to $(L_f - 1)$ in order to obtain the same output length of the UFMC modulator. Afterwards, OFDM and UFMC bands are up-converted to the desired intermediate carrier frequencies ($f_1 = 1.50$, $f_2 = 1.94$, $f_3 = 2.38$ GHz) and added together. Note that the IF of second and third bands are determined as follows $f_i = f_{i-1} + BW + GB$, where the guard-band (GB) is 40 MHz (10% of the BW). In order to avoid the second-order intermodulation distortions (IMD2) generated by the association of the SOA, the Mach-Zehnder modulator (MZM) and the photodiode (PD), the IF of the first band should be equal to or higher than 1.5 GHz in this case, according to our numerical study published in [1]. After passing by the digital to analog converter (DAC), the output is transformed into the optical domain by the laser ($P_{in_laser} = 10$ dBm, $\lambda = 1540$ nm) and the MZM characterized by a DC biasing voltage $V_{DC} = 1.5 V_\pi$ ($V_\pi = 6$ V). Indeed, the MZM transfer function could be expressed as:

$$P_{out_MZM}(t) = P_{in_laser} \cos^2 \left(\frac{\pi}{2V_\pi} (V_{DC} + V_{pp} S(t)) \right) \quad (1)$$

where $S(t)$ represents the normalized OFDM/UFMC signal, such that $\max |S(t)| = 0.5$. Before being transmitted through 20 km of single-mode fiber (SMF) ($D = 16.7$ ps/(nm.km); $\alpha = 0.2$ dB/km), the optical signal is amplified by the SOA ($I_{bias} = 200$ mA) which is modeled using Keysight Advanced Design System (ADS). At the receiver (Rx), the signal is converted back to electrical domain by the PD, transformed into digital domain and down-converted in order to obtain the three bands. A zero-forcing equalizer in the frequency domain is implemented at the Rx in order to compensate for the distortion incurred by the channel and also by the subband filtering in the UFMC case.

We firstly evaluate the error vector magnitude (EVM) performance of the OFDM/UFMC system without considering the SOA. By varying the peak to peak voltage V_{pp} from $0.1V_\pi$ to $0.9V_\pi$, the average EVM for the OFDM system is increased from 2.5% to 4.8% respectively, as depicted in Fig. 2 (a). In fact, higher values of V_{pp} push the MZM into its nonlinear regime (Eq. (1)) and induce consequently stronger IMDs at the PD output, causing this EVM degradation. We notice also that UFMC presents lower values of EVM in comparison with OFDM, for all V_{pp} values. Indeed, UFMC is more robust against inter-band interference than OFDM thanks to its lower OOBE, based on the subband filtering, as shown in Fig.1 (b). The average EVM is then examined in the presence of SOA, with and without its amplified spontaneous emission (ASE) noise, for different input powers P_{in} , at $V_{pp} = 0.5V_\pi$.

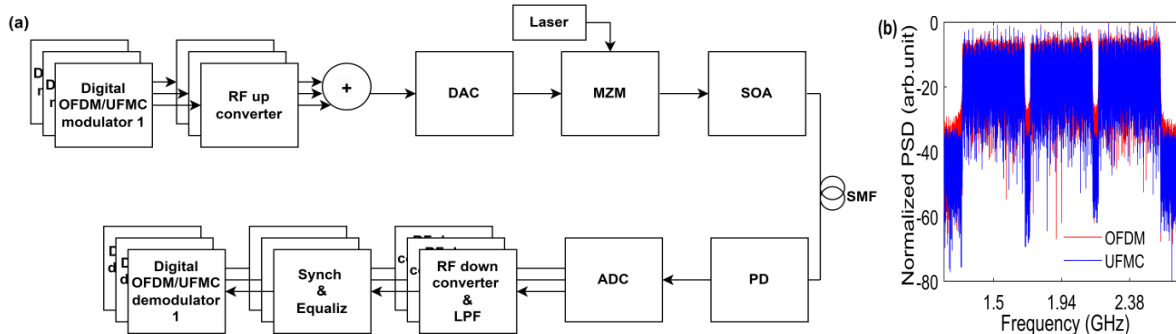

Figure 1. (a) Matlab/ADS co-simulation setup (LPF: lowpass filter; Synch: synchronization; Equaliz: equalization), (b) Power spectral density (PSD) of waveforms at the PD output ($V_{pp}/V_{\pi}=0.5$, $P_{in\ SOA}=-10$ dBm).

When simulated without the ASE noise (Fig. 2 (b)), UFMC outperforms OFDM in terms of EVM for all values studied of P_{in} , because of its tolerance to inter-band interference as previously explained. With ASE noise, at low P_{in} values (between -20 and -15 dBm), the SOA operates within its linear regime. Thus, the ASE noise effects are more dominant and high EVM values are thus obtained due to the low signal-to-noise-ratio (SNR) value of the Rx signals. In addition, we notice that OFDM presents slightly lower EVM values than UFMC in this region. In fact, the filter applied to each subband is not ideal, leading to a reduction in the average output power of the modulating UFMC signal and consequently to an EVM loss [2].

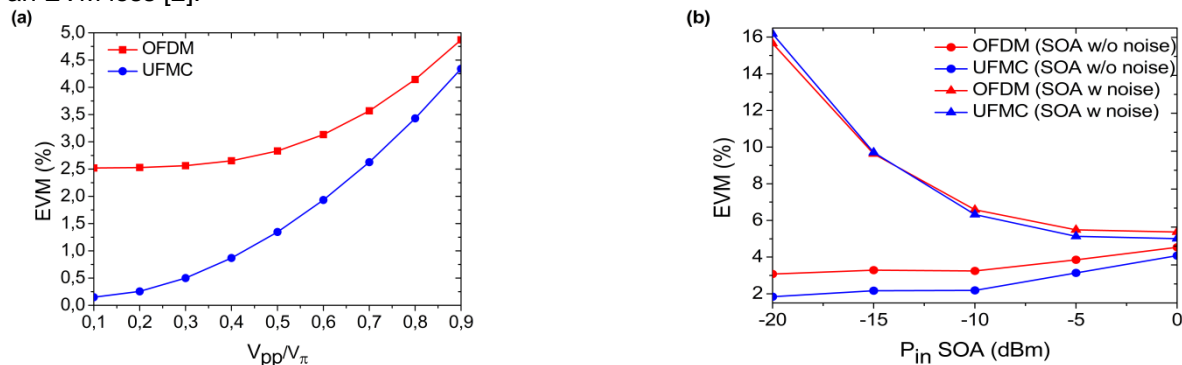

Figure 2. Average EVM performance for 3 OFDM/UFMC bands (a) vs V_{pp}/V_{π} (w/o SOA); (b) vs $P_{in\ SOA}$ (w SOA).

By raising P_{in} , the SNR is improved and the EVM decreases for both systems. With higher powers, the SOA ASE noise has less impact and the nonlinear effects of the SOA are more likely to appear. For this reason, UFMC presents better performance thanks to its lower OOB, as observed in the case of the SOA without noise.

Despite of being more vulnerable to the noise, UFMC should be considered over OFDM for 5G AIFoF fronthaul architecture since it may slightly enhance EVM performance while improving spectral efficiency not only by reducing guard bands thanks to its lower OOB, but also by eliminating the use of long CP.

Acknowledgments

This work was funded by the Brittany Region under the grant number SAD 2021 PROOF-Tx (21007843) as well as by the Departmental Council of Finistère within the framework of the APRE program (project 2021 PROOF-Tx).

References

- [1] M. Kasmi, P. Morel, M. Telescu, V. Choqueuse, N. Tanguy and S. Azou, "Influence of frequency mapping on intermodulation distortion in an SOA-based optical fronthaul C-RAN architecture for 5G communications", International Conference on Transparent Optical Networks (ICTON), Bucharest, Romania, July 2-6, 2023.
- [2] L. Zhang, A. Ijaz, P. Xiao, K. Wang, D. Qiao and M. A. Imran, "Optimal filter length and zero padding length design for universal filtered multi carrier (UFMC) system", IEEE Access, Vol. 7, p. 21687-21701, 2019.