



HAL
open science

Circularly Polarized In-Band Full-Duplex Antenna Array for Ka-Band Inter-CubeSat Links

Hadi Hijazi, Allan Pen, Marc Le Roy, Raafat Lababidi, Denis Le Jeune, André
Pérennec, Jean-Luc Issler, Kevin Elis, Jean-Herve Corre

► **To cite this version:**

Hadi Hijazi, Allan Pen, Marc Le Roy, Raafat Lababidi, Denis Le Jeune, et al.. Circularly Polarized In-Band Full-Duplex Antenna Array for Ka-Band Inter-CubeSat Links. 2022 20th IEEE Interregional NEWCAS Conference (NEWCAS), Jun 2022, Quebec, Canada. pp.80-83, 10.1109/NEW-CAS52662.2022.9842252 . hal-03760403

HAL Id: hal-03760403

<https://hal.univ-brest.fr/hal-03760403>

Submitted on 25 Aug 2022

HAL is a multi-disciplinary open access archive for the deposit and dissemination of scientific research documents, whether they are published or not. The documents may come from teaching and research institutions in France or abroad, or from public or private research centers.

L'archive ouverte pluridisciplinaire **HAL**, est destinée au dépôt et à la diffusion de documents scientifiques de niveau recherche, publiés ou non, émanant des établissements d'enseignement et de recherche français ou étrangers, des laboratoires publics ou privés.

Circularly Polarized In-Band Full-Duplex Antenna Array for Ka-Band Inter-CubeSat Links

Hadi Hijazi^{1,2}, Allan Pen^{1,2,3,4}, Marc Le Roy², Raafat Lababidi¹, Denis Le Jeune¹,
Andre Pérennec², Jean-Luc Issler³, Kevin Elis³, Jean-Hervé Corre⁴

¹ENSTA-Bretagne, ²Univ Brest, Lab-STICC, UMR 6285, CNRS, F-29200 Brest

³Centre National d'Etudes Spatiales (CNES), Toulouse; ⁴Syrlinks, Rennes

hadi.hijazi@ensta-bretagne.org

Abstract— this paper presents an 8 x 8 patch array with in-band full-duplex capabilities for Ka-band inter-CubeSat links that can be fitted on the surface of a 1U CubeSat. In simulation, the array can achieve 50 dB of self-interference cancellation and a very low axial ratio (< 1 dB) from 25 to 27 GHz by exploiting an approach of multilevel sequential rotation. The array also exhibits a wide matching bandwidth from 24.5 to 27.5 GHz and can achieve a gain higher than 20 dBi.

Keywords—circular polarization, CubeSats, in-band full-duplex, Ka-band, patch array, self-interference cancellation, simultaneous transmit and receive, STAR.

I. INTRODUCTION

The space surrounding the earth is being increasingly occupied by CubeSat constellations in the Low Earth Orbit (LEO). For instance, the global number of deployed CubeSats is estimated to be more than 1500 and is expected to increase in the upcoming years [1]. In the future, the rise in the number of deployed CubeSats will start to constitute a major concern for the performance of satellites' front ends, especially for antennas involved in inter-satellite links (ISL). In fact, the available spectral resources, whether for telemetry or ISL, are limited and shared among all members of a constellation, which means that some frequencies must be reused by multiple satellites in the swarm. This can lead to serious issues of mutual coupling and interference between the different satellites, not to mention the coupling from other satellites in higher orbits, which affects the quality of the communications and deteriorates the sensitivity of the satellite's receiver. This problem of inter-satellite interference can be avoided altogether by equipping the CubeSat with multiple antennas operating at different frequency bands. However, this solution can be demanding and costly, and aggravates the complexity of CubeSat antenna design process, especially considering the size limitations imposed by the CubeSat chassis standard.

An alternative solution that can mitigate the spectral resources scarcity problem is to use a single frequency (per satellite) simultaneously for uplink and downlink (i.e., to transmit and receive) instead of two separate frequencies. This theoretically doubles the spectral resources in the targeted frequency band, and it also doubles the throughput of the communication channel, which is vital for high data-rate communications. Nevertheless, using such approach is hindered by the strong self-interference (SI) resulting from the high power-coupling between the CubeSat transmitter and its own receiver, as they share the same radio front-end, which saturates the receiver and jams the signals received from other satellites. But, on the other hand, recently, in-band full-duplex (IBFD) technology emerged as a promising solution to this problem, as it achieves simultaneous transmission and reception (STAR) by implementing various self-interference

cancellation (SIC) techniques to suppress it to below the receiver's noise floor, such that it doesn't affect the receiver's signal-to-noise ratio [2]. The required level of SIC will depend on the strength of the signals arriving from other satellites, which will be weakened by distance, yet a simple link budget calculation reveals that the needed level of SIC is in the range of 110–130 dB. To achieve this level of cancellation, multiple cancellation circuitry must be implemented successively at different stages of the satellite's radio front-end, that is, at the antenna, analog and digital levels. Achieving high levels of cancellation at the antenna stage is of major importance to prevent the residual SI from saturating the receiver and degrading the resolution of the ADC.

IBFD can be considered as a nascent field of research that is still under development. Though many works in this field were published, yet only few publications exist on IBFD for CubeSats [3], thus, this domain needs to be investigated more. And any work in this domain needs to satisfy simultaneously the requirements of IBFD and CubeSat antenna standard. That is, the designed system must achieve the targeted level of SIC while providing a high gain and a good quality of circular polarization, and at the same time it needs to fit on the CubeSat's surface. In the first stage of our work, we are focused on achieving SIC at the antenna level only, and we seek to achieve at least 50 dB of cancellation at that level. At the same time, we aim to achieve at least 20 dBi of gain in the antenna design with an axial ratio (AR) much lower than 3 dB, while ensuring that the antenna can be fitted on the surface of a 1U CubeSat.

There are numerous SIC techniques available in the literature, the readers are encouraged to explore [4] for an exhaustive review, however, among all those techniques Near-Field Cancellation (NFC) [5] stands out as a superior SIC technique at the antenna level. NFC can achieve the required SIC level without affecting the far-field radiation of the antenna, unlike other techniques which need to direct the transmit and receive beams in different directions or to create a null in one of them. Based on that, here we present an array that combines the NFC technique, to obtain the targeted level of SIC, with the design of a sequentially fed patch array [6] that achieves a superior quality of circular polarization (AR < 1 dB) and a high gain (> 20 dB). The array occupies an area of 62 x 62 mm², which is smaller than the surface of a 1U CubeSat. To the best of the author's knowledge, this paper is the first to demonstrate a fully developed IBFD antenna array suitable for CubeSat applications.

The remaining of this paper will be organized as follows: Section II will present the different parts of the array and will briefly discuss the way it operates, while Section III will demonstrate its performance, and finally Section IV will conclude and point to future perspectives.

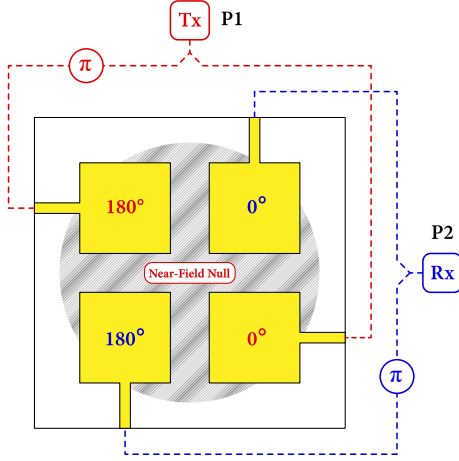

Figure 1: an illustration of a full-duplex patch array based on the near-field cancellation technique.

II. SYSTEM OVERVIEW

A. Full-Duplex Operation

In order to understand the principle of operation of the NFC technique, let's consider first the simple antenna array configuration in Figure 1. There are four patch antennas that are sequentially rotated around the center of the array forming two pairs of diagonally opposite antennas. By consequence, the two pairs of antennas will be orthogonally polarized, and for each pair the feeding transmission lines of the opposite antennas are oriented in opposite directions. After that, each pair will be connected to an external balun and one pair will be used to transmit while the other one will be used to receive. Any signal coming from the transmitter will be divided between the two Tx antennas into two parts of equal amplitudes and opposite phases. And once the two opposite signals get radiated by the Tx antennas they will interfere destructively in the near-field region creating a null plane (the shaded circle in Figure 1), especially along their perpendicular bisector. Since the Rx antennas are lying in the near-field region along the perpendicular bisector of the Tx antennas, then they should be shadowed by the null plane and should be totally isolated, in theory, from the Tx antennas.

In fact, the total isolation between Tx and Rx antennas is only true under ideal conditions, that is, if the baluns can actually divide the transmitted signal into two equal parts which are exactly out-of-phase, and if the array symmetry is totally achieved. Nevertheless, in practice there will always be some amplitude and phase imbalances in the baluns, and, also, the fabricated antennas might not have identical dimensions and might not be exactly symmetric around the center of the array. Therefore, the level of isolation, in practice, is expected to be finite. So, in order to boost SIC, the second balun, at the receiver side, can be used to compensate for the degraded isolation. Moreover, the cross-polarization between Tx and Rx antennas can also contribute up to 30 dB of SIC due to the inherent isolation between the orthogonal polarizations.

It should be noted that the balun at the receiver side only cancels self-interference and does not actually affect the useful signals coming from other satellites. In addition to that, the near-field null does not extend to the far-field region, and it does not affect the far-field radiation pattern of the array. And finally, although we have demonstrated the full-duplex

operation for a simple array, but the same principle can be applied for bigger arrays using a larger number of antennas.

B. Array Configuration

Figure 2 shows the configuration of the final full-duplex array. The array is formed of three metallic layers separated by two dielectric layers (Figure 2(a)). The two dielectric layers are both 0.254 mm thick RT5880 laminates with $\epsilon_r = 2.2$. The radiating elements are installed on the top layer (yellow colored), while the array feeding network is accommodated on the bottom layer (orange colored), and the middle layer (gray colored) acts as a ground plane. The radiating elements on the top layer are connected to the feeding network on the bottom layer using a group of vias (red colored). And although the feeding network and the radiating elements can be implemented on the same layer, however, here they were separated to prevent any direct coupling between the radiating elements and the feeding transmission lines. Otherwise, the radiation of the array might be affected and the effectiveness of self-interference cancellation can be degraded.

The design of the array takes into consideration both the specifications of the CubeSat standard and full-duplex technology, which were stated in the introduction:

- 1) To obtain a gain higher than 20 dBi, a 64 (8 x 8) element array is needed, taking into account that the gain of the single element is about 6.7 dBi at 26 GHz. However, note that only half this number of elements will be dedicated for downlink (to transmit) and the other half will be used for uplink (to receive). And for both links the gain remains higher than 20 dBi.
- 2) The width of the single patch is 3.7 mm and the spacing between the array elements (center-to-center distance) was kept at a feasible minimum of 7.7 mm. Accordingly the size of the whole array was found to be less than 62 x 62 mm². This ensures that the proposed array can fit on the surface of a 1U CubeSat.
- 3) The 8 x 8 array is divided into four 4 x 4 subarrays (hereinafter will be called Level-1 or L1 subarrays) and each L1 subarray is divided into four 2 x 2 subarrays (hereinafter will be called Level-0 or L0 subarrays). The L0 subarrays are formed of four patch antennas with truncated corners that are sequentially rotated around the center of the subarray. Then the four patches are connected to a sequential power divider that can provide a quadrature phase shift between the consecutive antennas. The rotation of the patches and the quadrature phase shift can greatly boost the quality of the circular polarization of the array. Thus, to enhance the axial ratio even more, the same approach is applied for L0 subarrays inside each L1 subarray, and also for L1 subarrays.
- 4) The geometrical rotation at every level of the array not only enhances the quality of circular polarization but is also a mandatory condition to obtain a high rotational symmetry in the system, which is needed for proper operation of the near-field cancellation technique.

For full-duplex operation, one pair of the diagonally opposite L1 subarrays will be used as Tx while the other pair will be used as Rx. Then each pair will be connected to an external balun as demonstrated in the Figure 1. However, there is a possibility to integrate the balun directly with the feeding network in the bottom layer as shown in Figure 2(e). The

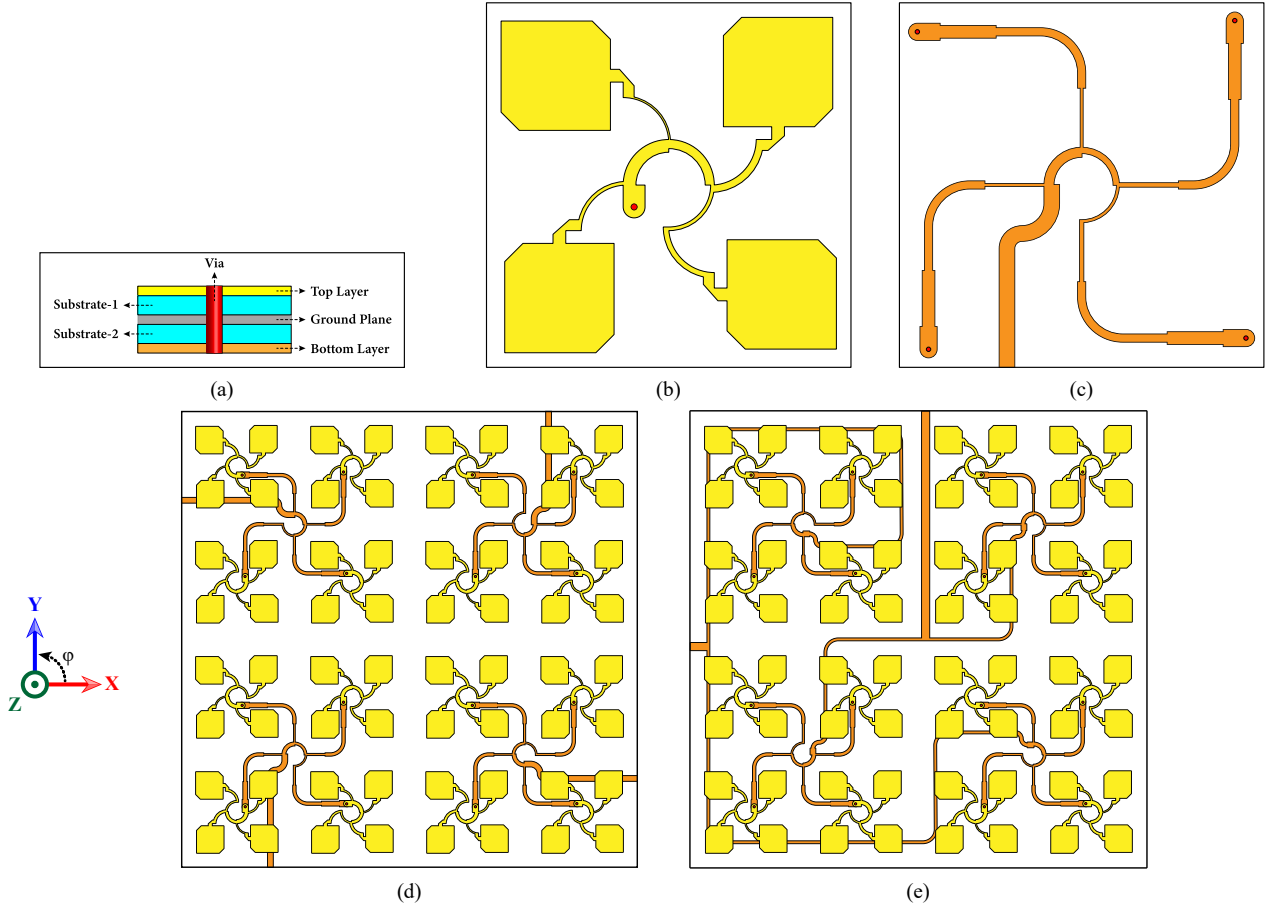

Figure 2: (a) the stack of layers constituting the array, (b) Level-0 subarray with four patches and sequential power divider, and (c) the feeding network for each four Level-0 subarrays inside each Level-1 subarray, (d) an 8 x 8 full-duplex patch array based on the configuration of Figure 1, (e) another patch array with an integrated balun. [Substrate-1, Substrate-2, and the Ground Plane are omitted from figures (d) and (e) for clarity].

balun in this case is implemented by using a simple T-junction power divider having an extra length of half-wavelength (at 26 GHz) in one of its outputs.

III. ARRAY PERFORMANCE

Three different array configurations were simulated in CST Microwave Studio: (i) the array configuration of Figure 2(d) connected to two ideal baluns with no phase or amplitude imbalances between their output ports. (ii) the same configuration but connected to commercially available baluns from Marki microwaves [7], such realized baluns tend to have some phase and amplitude imbalances ($\pm 4^\circ$ and ± 0.7 dB respectively). And (iii) the configuration in Figure 2(e) with the integrated balun. The aim of comparing these three configurations is to get an idea about what is the ideal performance of this array and what quality of performance could we expect later in measurements. The results of the simulations are depicted in Figure 3.

Starting with the system matching in Figure 3(a) it can be noticed that all the three configurations can achieve a relatively wideband matching. Though not all can cover the frequency range from 24 to 28 GHz, yet all of them are matched from 25.25 and 27.5 GHz, which is a standard frequency band for inter-satellite links (standard SFCG 15-2R4). In addition to that, Figure 3(b) depicts the levels of SIC obtained by each configuration. In the ideal case, the level of cancellation is in general higher than 120 dB, while in the other cases it remains higher than 40 dB (with an average

value of 50 dB). The difference in cancellation between the ideal case and the other configurations is expected, mainly, because in the non-ideal configurations there are some phase and amplitude imbalances between their output signals, and those imbalances can have a significant impact on the level of obtained cancellation.

Also Figure 3(c) demonstrates the gain and axial ratio of the array. It should be noted here that for all array configurations the gain and axial ratio values are almost identical, so only a single plot of each is shown here for clarity. The array can achieve a gain higher than 15 dBi from 25 to 27 GHz, however, it can achieve a gain higher than 20 dBi between 25.75 and 26.5 GHz. Keep in mind that this gain corresponds only to one link (uplink or downlink) which uses only half the number of patches. Moreover, the axial ratio remains lower than 1 dB in the frequency band from 25 to 27 GHz, and this wideband low axial ratio is one of the most prevailing features of the sequentially rotated array. Finally, Figure 3(d) depicts the radiation pattern cuts of the array in two planes: $\phi = 45^\circ$ and $\phi = 135^\circ$. Note here that due to the diagonal alignment of the opposite subarrays, the radiation pattern will be tilted by 45° from the x-axis. The radiation pattern in the $\phi = 135^\circ$ plane is directive with extremely low side lobes, while in the $\phi = 45^\circ$ plane the main beam is even more directive but with two significant grating lobes along its sides. In fact, the grating lobes develop in the radiation pattern whenever the separation distance between the centers of the radiating subarrays is larger than a half-wavelength (at 26 GHz), which is the case in the proposed array configuration.

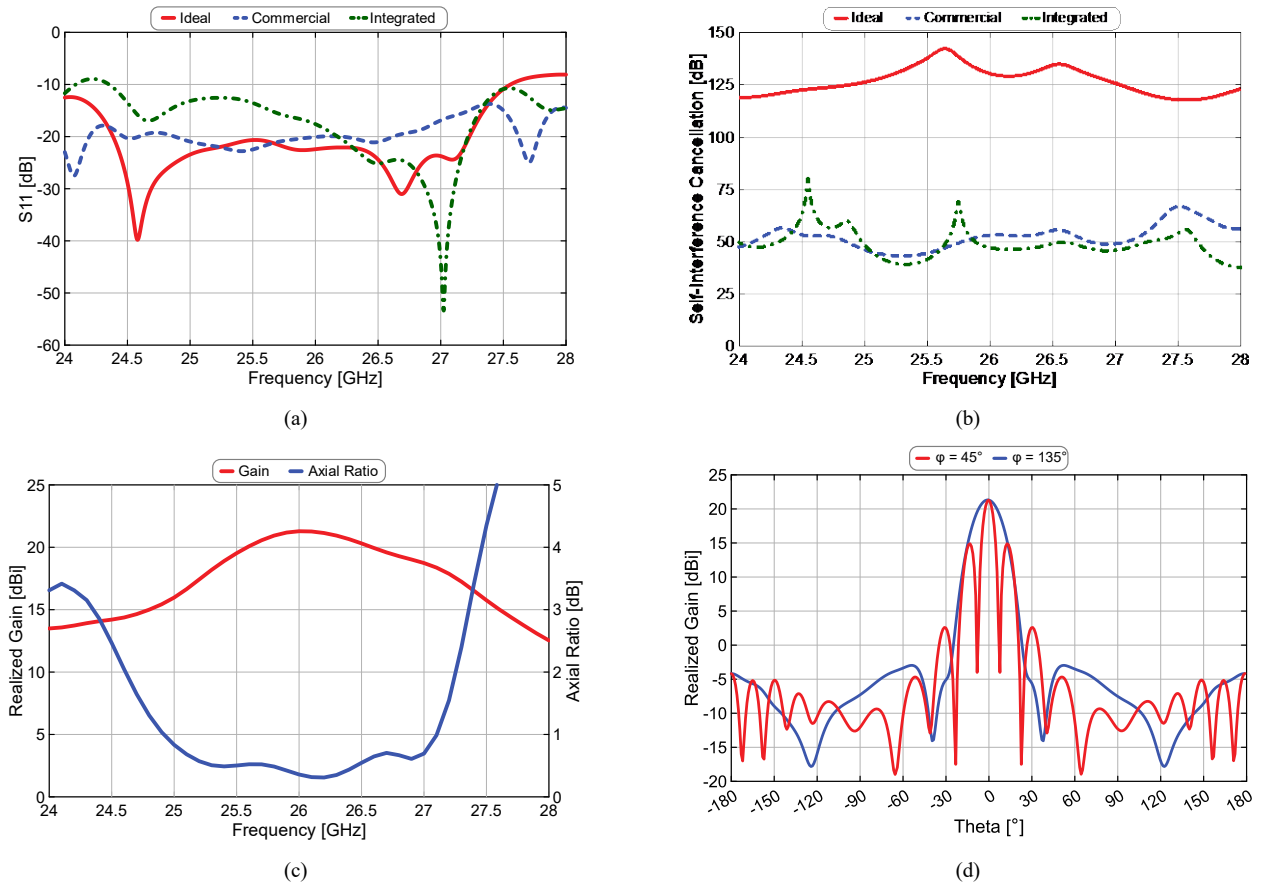

Figure 3: Simulated array (a) matching, (b) self-interference cancellation, (c) gain and axial ratio, and (d) a sample radiation pattern cut at 26 GHz.

The grating lobes cannot be totally eliminated unless the separation distance is reduced to a half-wavelength, which might not be feasible due to geometrical limitations.

IV. CONCLUSION

In summary, this paper presented an 8 x 8 patch array with in-band full-duplex capabilities for Ka-band inter-CubeSat links. The proposed array utilizes the near-field cancellation technique to achieve a level of self-interference cancellation higher than 40 dB (and 50 dB on average). And it exploits a multilevel sequential rotation approach to achieve a superior quality of circular polarization with an axial ratio < 1 dB from 25 to 27 GHz. The array is also characterized by a wide matching bandwidth from 24.5 to 27.5 GHz and can achieve a gain higher than 20 dBi in the frequency range from 25.5 to 26.5 GHz. Moreover, the total area of the array is 62 x 62 mm² making it possible to integrate on a 1U CubeSat surface.

There might be a way to exploit the full potential of the array by widening the gain bandwidth to fit the matching and axial ratio bandwidths. In fact, only half the array elements are used either for Tx or Rx and not all are radiating at the same time, which reduces the gain of each link by 3 dB. Nevertheless, there are some full-duplex works [8] that have proposed a way to use each single patch to transmit and receive simultaneously, without degrading the effectiveness of the near-field cancellation technique. This means that all array elements could be used simultaneously by both links and consequently increase their gain by 3 dB with probably a slight impact on the full-duplex performance. Moreover, this approach could contribute to the reduction of the grating lobes

in the radiation pattern of the array, as it reduces the separation distance between the L1 subarrays, and this distance is mainly controlled by the spacing between the array elements, which is in turn restricted by the geometrical shape and size of the sequential power divider feeding the patches.

ACKNOWLEDGMENTS

This project is supported by the French National Center of Spatial Studies (CNES) and the Syrlinks Company.

REFERENCES

- [1] E., Kulu, 2022, "Nanosats Database". [online] Available at: <https://www.nanosats.eu/> [Accessed 26 January 2022].
- [2] A. Riihonen & H. Suraweera, Full-Duplex Communications for Future Wireless Networks. Springer, 2020.
- [3] E. Grayver, R. Keating, and A. Parower, "Feasibility of full duplex communications for LEO satellite." In *2015 IEEE Aerospace Conference*, pp. 1-8. IEEE, 2015.
- [4] K. Kolodziej, B. Perry, and J. Herd, "In-band full-duplex technology: Techniques and systems survey." *IEEE Transactions on Microwave Theory and Techniques*, 2019, vol. 67, no. 7, pp. 3025-3041.
- [5] R. Wu, J., M. Li, N. Behdad, "A Wideband, Unidirectional Circularly Polarized Antenna for Full-duplex Applications", *IEEE Transactions on Antennas and Propagation*, 2018, 66, (3), pp. 1559-1563.
- [6] D. Inserra, W. Hu, and G. Wen, "Design of a Microstrip Series Power Divider for Sequentially Rotated Nonuniform Antenna Array." *International Journal of Antennas and Propagation*, 2017.
- [7] Marki Microwaves, 2022. "BAL-0050 Broadband Balun". [online] Available at: <https://www.markimicrowave.com/baluns/bal-0050.aspx> [Accessed 31 January 2022].
- [8] I. Tekin, and H. Nawaz. "Double-Differential Fed, Dual Polarized Patch Antenna System with Advanced Interport RF Isolation for IBFD Transceivers." U.S. Patent 10,756,436, issued August 25, 2020.