



**HAL**  
open science

# Hybrid Architecture of a Compact, Low-cost and Gain Compensated Delay Line Switchable From 1 m to 250 m for Automotive Radar Target Simulator

Fabien Arzur, Marc Le Roy, André Pérennec, Gérard Tanné, Nicolas Bordais

► **To cite this version:**

Fabien Arzur, Marc Le Roy, André Pérennec, Gérard Tanné, Nicolas Bordais. Hybrid Architecture of a Compact, Low-cost and Gain Compensated Delay Line Switchable From 1 m to 250 m for Automotive Radar Target Simulator. EuRAD (European Radar Conference) 2017, EuMW, Nuremberg, Germany, Oct 2017, Nuremberg, Germany. pp.1-4. hal-01589846

**HAL Id: hal-01589846**

**<https://hal.univ-brest.fr/hal-01589846v1>**

Submitted on 19 Sep 2017

**HAL** is a multi-disciplinary open access archive for the deposit and dissemination of scientific research documents, whether they are published or not. The documents may come from teaching and research institutions in France or abroad, or from public or private research centers.

L'archive ouverte pluridisciplinaire **HAL**, est destinée au dépôt et à la diffusion de documents scientifiques de niveau recherche, publiés ou non, émanant des établissements d'enseignement et de recherche français ou étrangers, des laboratoires publics ou privés.

# Hybrid Architecture of a Compact, Low-cost and Gain Compensated Delay Line Switchable From 1 m to 250 m for Automotive Radar Target Simulator

Fabien Arzur<sup>1,2</sup>, Marc Le Roy<sup>1</sup>, André Pérennec<sup>1</sup>, Gérard Tanné<sup>1</sup>, Nicolas Bordais<sup>2</sup>

<sup>1</sup>Lab-STICC, UMR CNRS 6285  
Université de Brest (UBO), Brest, France

<sup>2</sup>ZF TRW Autocruise  
29280 Plouzane, France  
fabien.arzur@zf.com

**Abstract**—An hybrid architecture of a compact, low-cost and gain compensated delay line switchable from 1 m to 250 m is presented in this paper. The delay line takes place in a Radar Target Simulator to allow testing automotive radar sensors. A hybridization of different technologies is presented to simulate delays on the entire range with a 20 cm resolution step and a frequency band of 800 MHz. Three technologies, LTCC components, optical fibers and SAW filters, were combined to cover the entire distance range. The whole system also ensures a gain compensation and equalization in the entire frequency band, as well as the simulation of the Radar Cross Section (RCS) of various targets over the entire distance range.

**Keywords**— radar; radar target simulator; automotive radar; group delay; delay line; tunable delay; RCS; wideband

## I. INTRODUCTION

In order to offer vehicles always safer, manufacturers develop more and more efficient Advanced Driver Assistance Systems (ADAS). Among these systems, we observe a democratization of automotive radar sensors for collision warning and adaptive cruise control. Radars provide functions such as Automatic Emergency Braking (AEB) or Adaptive Cruise Control (ACC) for example. We can easily imagine that all vehicles will be equipped by one or several radar sensors in a few years. This perspective will impose to automotive manufacturers, dealerships and technical control centers to have test systems allowing complete control and verification of radars.

To achieve the characterization, tests and calibration in reliable and repeatable conditions, we need to use an automotive Radar Target Simulator (RTS). The simulator must be able to simulate all situations encountered by the radar (urban and highway detection, pedestrians, cars...). Thanks to a high angular resolution, radars have to be able to differentiate a cyclist to a pedestrian. These many scenarios are becoming increasingly complex, especially with the arrival of autonomous vehicles. A simulated target is defined by three parameters: speed, distance and Radar Cross Section (RCS). Some existing RTSs correspond to future radar specifications in terms of performances but none fulfils specifications in compactness, flexibility, and

low-cost suitable for an enlarged diffusion. A general schematic diagram of a RTS is illustrated in the Fig. 1.

In this work, the design of a new delay line architecture, hybrid, compact, low-cost and compensated in magnitude and delay is presented. Section II describes problematics and the RTS topology. A hybrid architecture that merges different technologies is introduced in section III. The different technologies are compared according to of their delay range, cost and compactness. A gain equalization circuit is also proposed. Section IV will detail the RCS control. Prospects and conclusions are finally drawn.

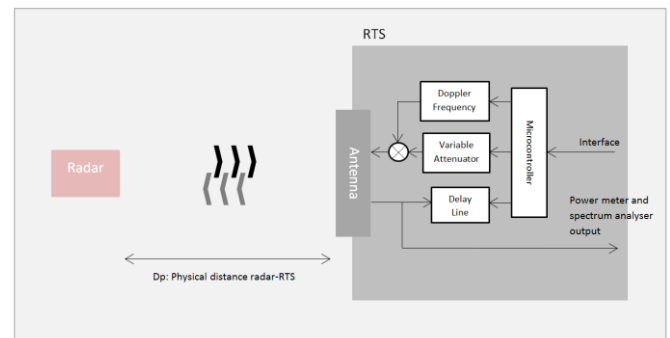

Fig. 1. Radar Target Simulator principle.

## II. PROBLEMATICS

To meet radar sensors specifications, ZF TRW Autocruise Compagny designs its own Radar Target Simulators specifically for automotive radar sensors for production test bench and R&D laboratory.

RTS has to work at frequency bands of 24 GHz and 76 – 81 GHz, with frequency bandwidth better than 800 MHz and different modulations. To be integrated in different configurations, the simulator has to be sufficiently flexible, scalable, polyvalent, with small dimensions (< 15 cm x 5 cm x 5 cm) and at low cost (< 2000 €).

The velocity of a moving target is generated by a frequency shift following Doppler Effect. The speed range is from 0 to 250 km/h.

In the design of a RTS, the main blocking point is the distance generation on a large frequency band with a fine resolution. The distance is simulated by a time delay of the signal. The distance ranges from 1 m to 250 m, corresponding to delays from 6.67 ns to 1.67  $\mu$ s respectively and the resolution of the delay line has to be better than 20 cm (1.3 ns). A compromise has to be found between performances, low-cost and small size. The main problematic will consist in the simulation of the entire range of delays while maintaining the high resolution.

Another bottleneck is the simulation of the RCS of a target. The RCS is adjusted with a gain/attenuation control according to the size of the target to simulate.

The RTS front end operates at intermediate frequency. So, the working frequency of both the variable delay line and the RCS section will be between 1 and 2 GHz (L band) which allows a wider and more varied technologies choice.

It should be noted that, due to internal components of the RTS (excluding the delay line), the minimum simulated distance will be at least 10 m.

### III. HYBRID ARCHITECTURE

A state-of-the-art and a comparative study of delay lines were realized in order to identify the available technologies with their drawbacks and their advantages following the delay range. Fully digital delay lines using analog-to-digital converter and digital signal processing techniques exist and are used in some commercial automotive RTS. However, their very high costs do not allow a wide distribution of RTS. Among the analog techniques, it has been shown the impossibility to generate the entire range of delays and the desired resolution with only one technology. A hybridization of technologies is essential to meet specifications, particularly in term of costs and volume.

#### A. Technology benchmarking

Depending on the desired delay it is possible to choose between different technologies as coaxial cables, optical fibers, Surface Acoustic Wave (SAW) filter [1], Bulk Acoustic Wave (BAW) filter, LTCC (Low Temperature Co-fired Ceramic) [2] or low-cost planar technology, e.g. meander lines delay lines, true-time delay phase shifters [3] or Reflection Type Phase Shifter (RTPS) [4] among many others.

The following comparison only deals on switchable and tunable analog delay lines. To reduce costs, available Commercial Off-The-Shelf (“COTS”) components are privileged in a first time.

As depicted in Fig. 2.a, delay and cost versus the relative size for the available technologies follows globally the same distribution. On the other hand, Fig. 2.b illustrates insertion losses versus size.

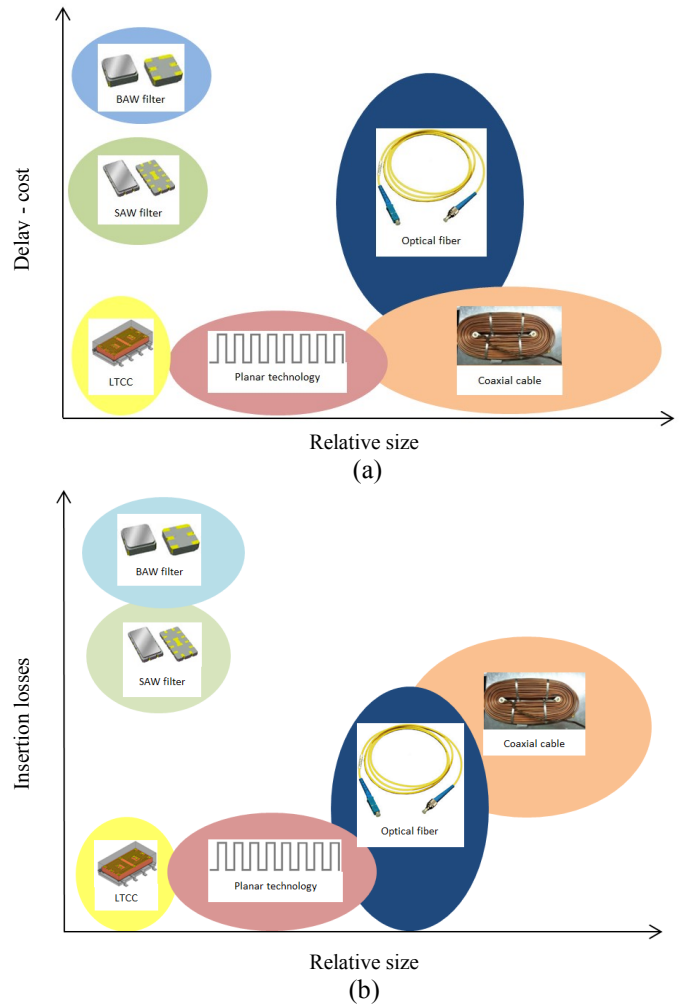

Fig. 2. State-of-the-art technologies: (a) Delay and cost vs Size, (b) Insertion losses vs Size.

Table I. sums up the advantages and drawbacks of these technologies according to their delay range, bandwidth, insertion losses, size, complexity of integration and cost. Three technologies are highlighted: LTCC technology, optical fibers, and SAW filters. Planar technologies offer, for example, the possibility to design true time delay phase shifters with good performances, but with a poor flatness of group delay over a wide bandwidth compared to other techniques. Thus, this solution will not be retained.

Table I. Technologies benchmarking .

| Technologies      | Delay range | Bandwidth | Insertion Loss | Size | Simplicity | Cost   | Total |
|-------------------|-------------|-----------|----------------|------|------------|--------|-------|
| Coaxial cable     | ns          | -         | -              | -    | +          | \$     | 2     |
| Optical fiber     | ps- $\mu$ s | +         | +              | +    | +          | \$\$   | 5     |
| SAW filter        | ns          | +         | -              | +    | -          | \$\$   | 3     |
| BAW filter        | ns          | +         | -              | +    | -          | \$\$\$ | 2     |
| Planar technology | ps-ns       | -         | -              | -    | +          | \$     | 2     |
| Lumped element    | ps          | -         | +              | +    | +          | \$     | 4     |

Table II. details relations between delays and the corresponding simulated distances and the optimal technology for each delay range in order to cover the full

distance range. The system is composed of delay blocks from 0.2 m to 128 m. To assure a fine resolution, four 20 cm LTCC-blocks complete the delay line whereas the most important delays are generated by SAW filter. Indeed, they present the most interesting delay/size ratio among candidates despite high insertion losses. Available commercial SAW filters had been tested; then, they have been redesigned to get specific delays corresponding to distances from 16 m to 128 m. Intermediate delays, not achievable by SAW filter, are simulated with optical fibers. They allow simulating 4 and 8 m distances with very low insertion losses on a wide frequency band. Small distances (< 4 m) and the unit resolution are generated by very small LTCC components. Prototypes of each delay blocks had been designed, implemented and measured separately.

Table II. Relation between simulated target distances and delays for selected technologies.

| Technology   | LTCC delay line |      |      |      | Optical fiber |      | SAW filter |     |     |     |
|--------------|-----------------|------|------|------|---------------|------|------------|-----|-----|-----|
| Delays (ns)  | 1.3             | 3.34 | 6.67 | 13.3 | 26.7          | 53.3 | 107        | 213 | 427 | 853 |
| Distance (m) | 0.2             | 0.5  | 1    | 2    | 4             | 8    | 16         | 32  | 64  | 128 |

### B. Global architecture of the delay line

Fig. 3 shows the design and the global architecture of the delay line. The compensation of the measured insertion losses has been studied, optimized and included in each delay block. It consists of an amplifier combined with an equalization of both the gain value and its slope to get a flat 0 dB insertion loss in each delay section.

Moreover, an amplifier and an attenuator both tunable are combined with a gain equalization circuit at the end of the whole delay line to compensate for the global chain, i.e. to compensate for the sum up of all residual contributions when all the delay sections are by-passed. SPDT (Single-Pole-Double-Through) switches are used to switch between different delay blocks to cover the range from 1.3 ns to 1.67  $\mu$ s with a 1.3 ns step. The microcontroller commands the switches and the regulation of the amplification/attenuation to obtain the desired target distance and RCS. RF detectors are placed at input and output to define the gain of the delay line and to adjust the gain of the RTS.

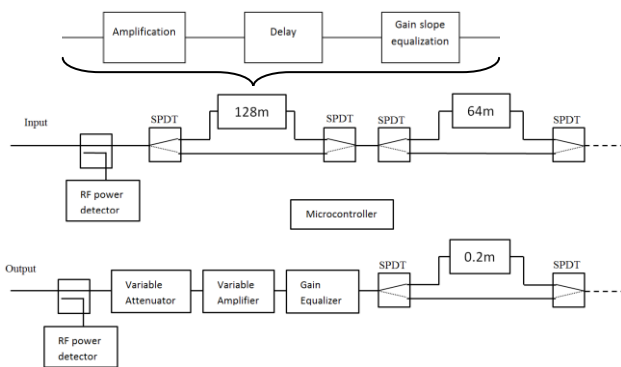

Fig. 3. Delay block and delay line architectures.

### C. Gain compensation and equalization

Each delay elements introduce insertion losses that increase depending on the frequency. To keep the signal integrity, low noise amplifiers are used to compensate insertion losses and not to degrade significantly the noise factor. Then, the equalization circuit is inserted and optimized with a good gain flatness as main goal and the preservation of the group delay flatness as the minor one.

Many topologies of equalizer had been tested. The range of the gain variation on a broadband frequency as well as the flexibility are the main criteria of choice. The equalization circuit (Fig. 4) is realized with a non-reflective filter designed with lumped elements [5]. It allows a wide flexibility in attenuation slope (Fig. 5.b) and a well-matched behavior (better than -20 dB). Different optimized versions of this circuit had been designed depending on S-Parameters of prototypes delay blocks.

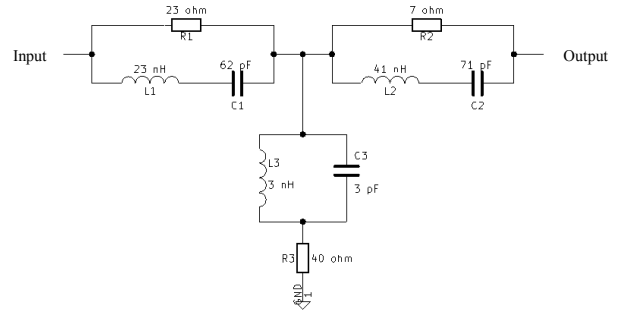

Fig. 4. Topology of a non-reflective filter.

Fig. 5 illustrates simulations of the  $S_{21}$  behavior for a specific delay block. The initial curve describes the insertion losses of LTCC components used to simulate a 2 m distance. Insertion losses are between -10.5 and -7 dB. The  $S_{21}$  parameters of the optimized equalizer alone and of the final zero-gain block are also depicted.

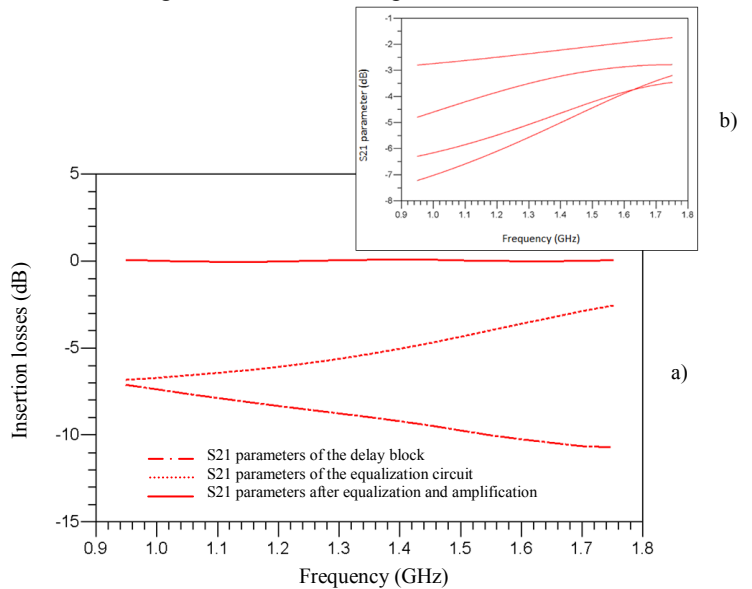

Fig. 5. (a) Simulations of  $S_{21}$  parameters of a delay block before/after equalization and amplification, (b) illustration of gain-slope possibilities of the proposed equalization circuit.

Fig. 6 show simulated group delay possibilities (up to the maximum value) for the whole system. These simulations take into account S-parameters of SPDT switches from suppliers and the measured delays of the different delay blocks.

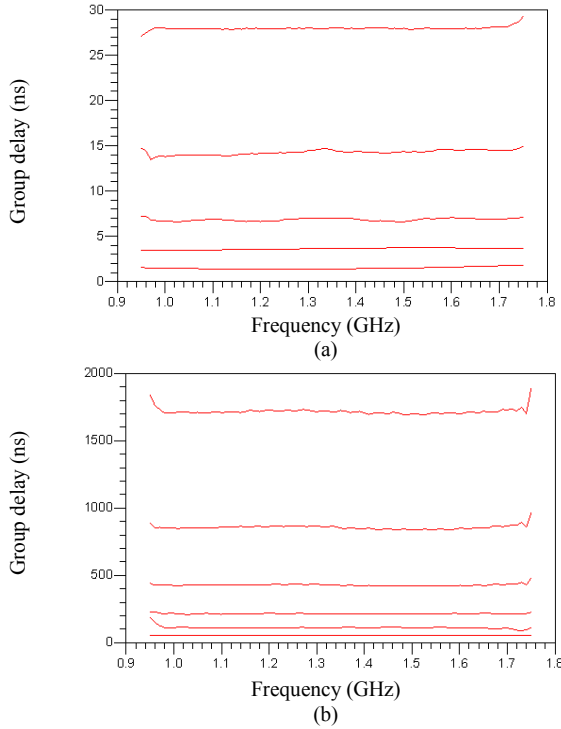

Fig. 6. Group delay simulations of the whole delay line, (a) from 1.3 ns to 26.7 ns, (b) from 53.3 ns to 1.67  $\mu$ s.

The 800 MHz of bandwidth frequency are not fully achieved. SAW filters introduce rises of the group delay at both sides of the band.

#### IV. RCS CONTROL

The RCS is a physical property that represents the ability of an object to reflect an electromagnetic wave. The RCS equation (1), the radar equation and losses from free-space path loss (2) allow determining the RCS equation (3) according to the gain of the RTS and of the simulated distance.

$$RCS = Pr + 10 \cdot \log_{10} \left( \frac{(4 \cdot \pi)^3 \cdot Ds^4}{\lambda^2} \right) - Pe - 2 \cdot Ge \quad (1)$$

$$Pr = Pe + 2 \cdot Ge + 40 \cdot \log_{10} \left( \frac{\lambda}{4 \cdot \pi \cdot Dp} \right) + 2 \cdot Ga + G_{RTS} \quad (2)$$

$$RCS = G_{RTS} + 10 \cdot \log_{10} \left( \frac{\lambda^2}{4 \cdot \pi} \right) + 40 \cdot \log_{10} \left( \frac{Ds}{Dp} \right) + 2 \cdot Ga \quad (3)$$

$G_{RTS}$  is the gain of the RTS,  $Pe$  is the power output of the radar and  $Ge$  the gain of the radar antenna.  $Pr$  represents the power received by the radar.  $Ds$  is the simulated distance by the RTS,  $Dp$  is the physical distance between the radar and the RTS and  $Ga$  the gain of the RTS antenna. The gain of the RTS has to be adjusted with the desired target size.

Table III details the correspondence between the selectable-size of the target and the RCS value. The RCS setup also takes into account the radar-RTS distance when the RTS is in a test bench.

Table III. RCS values at 77 GHz.

| Objects    | RCS (dBm <sup>2</sup> ) |
|------------|-------------------------|
| Pedestrian | -5 to -3                |
| Motorbike  | 3 to 5                  |
| Car        | 10 to 20                |
| Truck      | 20 to 45                |

Detectors based on RF couplers allow adjusting the gain value of the RTS to simulate the desired RCS depending on the under test scenario by attenuating or amplifying the signal. Table IV recapitulates the different values of attenuation and amplification following targets to simulate with equalization, i.e.  $G_{RTS} = 0$  dB.

Table IV. Attenuation/amplification according to the simulated distance and target.

| Simulated distance (m) | Pedestrian |    | Motorbike |   | Car   |    | Truck |    |
|------------------------|------------|----|-----------|---|-------|----|-------|----|
|                        | -5         | -3 | 3         | 5 | 10    | 20 | 20    | 50 |
| 10                     | -30.9      |    | -22.9     |   | -11.9 |    | 5.12  |    |
| 50                     | -58.8      |    | -50.8     |   | -39.8 |    | -22.8 |    |
| 100                    | -70.9      |    | -62.9     |   | -51.9 |    | -34.9 |    |
| 150                    | -77.9      |    | -69.9     |   | -58.9 |    | -41.9 |    |
| 200                    | -82.9      |    | -74.9     |   | -63.9 |    | -46.9 |    |
| 250                    | -86.8      |    | -78.8     |   | -67.8 |    | -50.8 |    |

The two extreme cases are the simulation of a truck at a low distance (10 m) and the simulation of a pedestrian at a high distance (250 m). The amplification/attenuation range will be larger than 90 dB.

#### V. CONCLUSION

This study shows the possibility of designing a delay line switchable from 10 m to 250 m for automotive radar sensors by using a hybrid architecture which is compact, low-cost and gain compensated. The innovation is mostly at a system level and comes from an architecture specifically developed around components, carefully selected according to the criteria of cost, delay, insertion losses and size. The whole final prototype is under completion and should meet the under 2000 € cost-constraint and the expected size (15 cm x 5 cm x 5 cm).

#### REFERENCES

- [1] A. Shirakawa, 'Etude, synthèse et réalisation de filtres BAW pour applications mobiles', Ph.D Thesis, Université de Bordeaux I, France, 2006.
- [2] H. Jiang and R.-M. Xu, '9.5 GHz 16 lambda G Delay Line Using Multilayer LTCC', *Prog. Electromagn. Res. Lett.*, vol. 6, pp. 175–182, 2009.
- [3] G.-L. Tan, R. E. Mihailovich, J. B. Hacker, J. F. DeNatale, and G. M. Rebeiz, 'Low-loss 2- and 4-bit TTD MEMS phase shifters based on SP4T switches', *IEEE Trans. Microw. Theory Tech.*, vol. 51, no. 1, pp. 297–304, Jan. 2003.
- [4] G. Chaudhary, H. Choi, Y. Joeng, J. Lim, and C. D. Kim, 'Design of Group Delay Time Controller Based on a Reflective Parallel Resonator', *ETRI J.*, vol. 34, no. 2, pp. 210–215, Apr. 2012.
- [5] A. Fejzuli, R. Kaarsberg, and N. Roldan, 'Broadband amplifier gain slope equalization with a single passive component', *High Freq. Electron.*, vol. 5, no. 6, pp. 22–26, 2006.