



HAL
open science

Small-Size and Low-Cost Wideband 800 MHz Delay Line Tunable from 1.3 ns to 1.67 μ s for Automotive Radar Sensor

Fabien Arzur, Marc Le Roy, André Pérennec, Gérard Tanné, Nicolas Bordais

► **To cite this version:**

Fabien Arzur, Marc Le Roy, André Pérennec, Gérard Tanné, Nicolas Bordais. Small-Size and Low-Cost Wideband 800 MHz Delay Line Tunable from 1.3 ns to 1.67 μ s for Automotive Radar Sensor. IEEE MTT-S 2017 International Conference on Microwaves for Intelligent Mobility: ICMIM2017, Mar 2017, Nagoya, Japon. pp.1-4. hal-01507282

HAL Id: hal-01507282

<https://hal.univ-brest.fr/hal-01507282v1>

Submitted on 12 Apr 2017

HAL is a multi-disciplinary open access archive for the deposit and dissemination of scientific research documents, whether they are published or not. The documents may come from teaching and research institutions in France or abroad, or from public or private research centers.

L'archive ouverte pluridisciplinaire **HAL**, est destinée au dépôt et à la diffusion de documents scientifiques de niveau recherche, publiés ou non, émanant des établissements d'enseignement et de recherche français ou étrangers, des laboratoires publics ou privés.

Small-Size and Low-Cost Wideband 800 MHz Delay Line Tunable from 1.3 ns to 1.67 μ s for Automotive Radar Sensor

Fabien Arzur^{1,2}, Marc Le Roy¹, André Pérennec¹, Gérard Tanné¹, Nicolas Bordais²

¹Lab-STICC, UMR CNRS 6285
Université de Brest (UBO), Brest, France

²ZF TRW Autocruise
29280 Plouzane, France
fabien.arzur@zf.com

Abstract—A small-size and low-cost wideband delay line tunable over a 1250:1 delay range is presented in this paper. The delay line should take place afterward in an automotive radar target simulator. The initial specifications require merging different technologies to simulate the desired distances from 0.2 m to 250 m with a high resolution and a large frequency band better than 800 MHz. Three technologies are highlighted, SAW filters, optical fibers and LTCC components, to generate delays between 1.33 ns and 1.67 μ s. Prototypes were realized, tested and characterized for each technology. Moreover, a hybridization of these technologies is proposed together, with the whole delay line simulations.

Keywords—delay line; radar; radar target simulator; group delay; tunable delay; wideband

I. INTRODUCTION

Today, we are witnessing a democratization of automotive radar sensors for adaptive cruise control and collision warning. Organizations like EuroNCAP encourage greatly automotive manufacturers, via an elaborated system of notation, to endow vehicles with more efficient security systems. Radars are key actors in advanced driver assistance systems. They provide functions such as Adaptive Cruise Control (ACC) or Automatic Emergency Braking (AEB). These systems are made available or standard on new vehicles thanks to lower costs. The generalization of radar use on all standard vehicles in the coming years will require an increased use of testing devices in equipment manufacturers, dealerships and technical control centers.

In order to characterize, test and calibrate radars in repeatable and reliable conditions, it is necessary to use Radar Target Simulator (RTS). These devices allow testing all situations encountered by the radar (cars, pedestrians, urban or highway detection). The aim of a RTS is to simulate three parameters: distance, speed and Radar Cross Section (RCS). However, existing simulators do not simultaneously meet future radar specifications nor cost and compactness consistent with a wider distribution of RTS. The Fig. 1 illustrates the schematic diagram of a RTS.

This paper will focus on the design of a wideband tunable delay line which is the main blocking point toward the design

of a small-size and low-cost RTS. Section II will detail the main challenges and the RTS topology. A benchmark based on cost and size criteria is proposed in section III to select the most relevant approaches to simulated different distances. The proposed architecture is described in section IV through simulated and experimental results. Some conclusions and prospects are finally drawn.

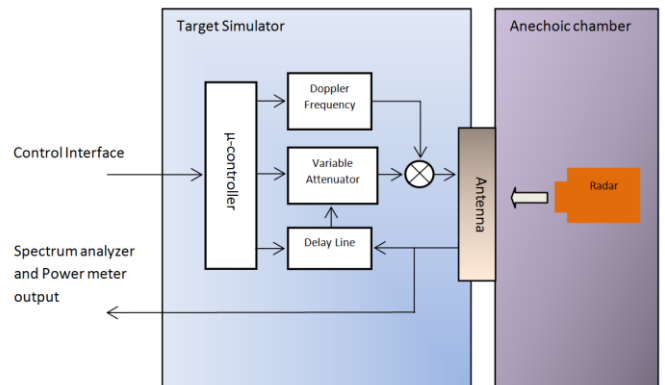

Fig. 1. Radar Target Simulator principle.

II. CHALLENGE

The ZF TRW Autocruise Company develops its own RTS to best meet radar sensors specifications. Simulators will have to adapt any radar operating in the frequency band 24 GHz and 76 – 81 GHz, with different modulations and frequency bandwidth better than 800 MHz. The system must be low cost, with small size and sufficiently flexible to be integrated in different configuration.

To simulate a speed of a moving target, the signal has to be shifted in frequency following Doppler effect. The speed range is between 0 and 200 km/h.

The main bottleneck in RTS is the distance simulation that requires a wideband variable delay line used to simulate a time-domain shift of the signal. The delay line has to simulate a distance between 0.2 m and 250 m (which corresponds to delays between 1.3 ns and 1.67 μ s). The resolution of the delay line will be better than 20 cm (1.3 ns). The system will

operate at intermediate frequency and cover the frequency range of 1 – 2 GHz (L band).

The delay line should allow adjusting the RCS of the simulator by a gain control to simulate different sizes of target like pedestrian, cyclist, car or truck.

A compromise should be done between low cost, small sizes and performances. The main difficulty relies on the wide range of delays to be simulated while keeping expected resolution.

The aim of the delay line is to vary the group delay (1) of the signal to simulate different distances, the group delay is the negative derivative of the phase in transmission versus frequency.

$$\tau = -\frac{\partial\varphi}{\partial\omega} \quad (1)$$

It must be noticed that due to the intrinsic parameters of the simulator, the RTS will finally simulate distances ranging from 10 m to 250 m.

III. BENCHMARK OF TECHNOLOGIES

A state-of-art and comparative study of delay line is proposed in order to identify the available technologies with their advantages and drawbacks following the delay range. Fully digital delay lines through ADC/DSP/DAC systems operating at intermediate frequency are already used in commercial automotive RTS. These RTS are able to simulate complex dynamic scenario but up to 4 targets and at a prohibitive cost that prohibits for now a widespread distribution. Thus, the following comparison only relies on analog tunable or switchable delay lines.

A. Comparison of available approaches

- The use of coaxial cable is still widespread in the realization of delay lines due to its low cost and ease of use. However, insertion losses are important for long delays and increase with frequency. Moreover, coaxial cables become bulky and heavy for large delay values [1].

The optical fiber allows to simulate an important range of distance (a few picoseconds up to many microseconds), with low insertion losses (<1 dB/km). Dimensions are lower than coaxial cables delay line. This technology offers the advantage to work on a bandwidth of several GHz and to have several possible topologies. However, this technology needs a RF-optical transposition and achieving a continuous tunable delay is possible but at a cost and size not compatible with our application.

- The SAW (Surface Acoustic Wave) technology converts electric energy of a wave in a mechanical energy at the input and inversely at the output. The propagation velocity is thus much lower than for electromagnetic waves since the acoustic wave travels at velocities of 3000 to 12000 m/s. SAW filters allow simulating delays from few nanoseconds to several hundred nanoseconds with frequency bandwidth that can reach 800 MHz. Their main disadvantages are

insertion losses (> 25 dB) and the frequency limitation (2.5 GHz). On the other hand, the small size (< 35 mm²) is particularly promising to simulate long delays for such applications [2]. It should be pointed out that no-tunability can be achieved.

- The BAW (Bulk Acoustic Wave) technology allows realizing a range of delays more important than SAW filters, from few hundreds of nanoseconds to several thousand microseconds. This technology overcomes the frequency limitation of SAW filters (2.5 GHz) and reaches frequencies of about 20 GHz with a frequency bandwidth up to 1 GHz. BAW filters offer the advantage of small dimensions (< 35 mm²). However, insertion losses are high (> 30 dB) and depend on the delay and the operating frequency. The cost also proves to be expensive at high frequency and for large bandwidth [3].
- The LTCC (Low Temperature Co-fired Ceramics) technology allows realizing electronic or microwave circuits, such as delay lines, filters... This technology is suitable to simulate low delays (few nanoseconds). The LTCC components offer significant advantages in terms of compactness (< 10 mm²), low cost, availability in different delay values, low insertion losses (< 1 dB) and a large frequency bandwidth (> 1 GHz) [4]. LTCC delay lines achieve these performances by using a high density of RF folded or meander lines which are distributed within high-k multilayer stacks.
- A large choice of approaches to design delay line on classical RF planar technology (microstrip, CPW, ...) is available, e.g. meander lines, spirals, filters with flat group delay, preferably on high permittivity substrates. This technology allows simulating low delays (few nanoseconds) with, in general, dimensions proportional to the operating wavelength, excepted when lumped components or “metamaterial slow-line” are used to achieve a significant velocity reduction ratio [5]. By using superconducting properties, performances of distributed lines can be clearly improved in terms of insertion losses, dimensions or frequency bandwidth [6]. However, constraints like cost, complexity and dimensions of this technology are not compatible with the desired specifications. By using reflection topologies with resonators including varactors at the reflection termination, it is possible to achieve tunable low delays (< 4 ns). The variation of group delay is interesting for an adjustment of the delay/distance but the bandwidth can't exceed 100 MHz [7]. Moreover, increasing the bandwidth comes at the expense of the delay value. Globally, RF distributed delay lines, despite their great design flexibility, their ease of implementation and the continuous-tuning possibility are systematically: i) more bulky than LTCC for small delay values or ii) more greatly lossy than optical fiber and even than SAW filter for high delay values.

From this state-of-art comparison, it is obvious that despite an enormous amount of research efforts, none of these approaches is still able to meet simultaneously the full delay range, the low-cost and small size specifications. Whereas, commercial off-the-shelves delay lines combined together seems currently to be the best solutions to meet these tough specifications.

B. Experimental verifications

Following these criteria, three of them stand out, SAW filters, optical fibers and LTCC components. Prototypes of each technology had been realized, tested and characterized in order, first, to verify the range of delays that can be achieved for each approach, secondly, to estimate the return losses and finally the flatness over the entire bands. These experimental validations will also be considered to improve the whole efficiency of the final combination.

- We choose SAW filters to generate the longest delays due to an unbeatable delay-size ratio compared to optical fibers despite higher losses. Available commercial SAW filters were initially selected, and then specifically redesigned to generate delays between 107 and 427 ns suitable for our application [8]. A filter on an evaluation board had been characterized (Fig. 2) for a 800 MHz bandwidth, the group delay is around 300 ns which corresponds to 90 m in free space and simulates a target at a distance of 45 m. Insertion losses higher than 31 dB will of course need to be compensated. A specific PCB design is under completion to improve both delay and insertion losses flatness.

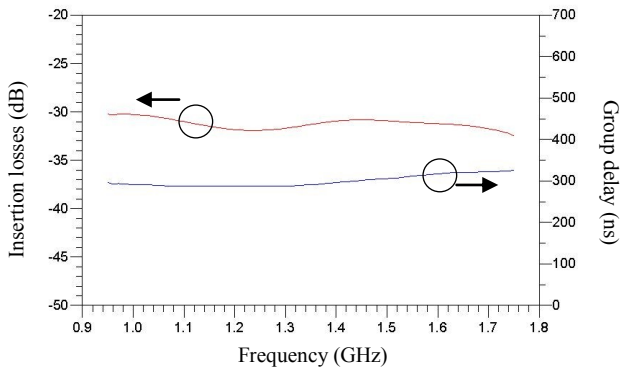

Fig. 2. Measurements of insertion losses and group delay of a SAW filter.

- Intermediate delays will be created with optical fibers due to an interesting trade-off between delays, insertion loss and compactness. This technology allows generating delays with low insertion losses and a wideband frequency (> 5 GHz). A specific prototype with RF-Optical modules had been designed [9] on a low cost PCB. The whole system (TX + RX) with a 5 m optical

fiber exhibits a small gain of 1 dB and a 30 ns delay in the considered band.

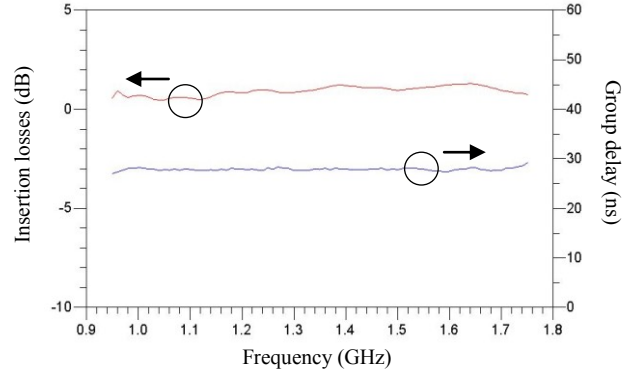

Fig. 3. Experimental S21 parameter and group delay values of the RF-optical-RF prototype.

- Small distances will be simulated by LTCC components which present currently the best group delay/size ratio in that range [10]. Boards with LTCC components had been designed and characterized. The insertion losses and group delay measurements of one of them are showed in Fig. 4, providing respectively 1.5 dB and 1.3 ns which corresponds to the resolution of the delay line.

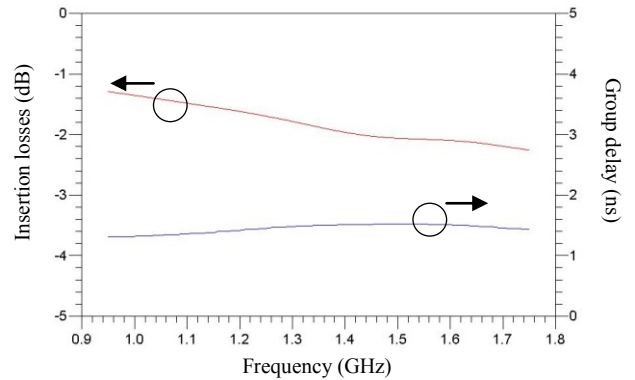

Fig. 4. Insertion losses and group delay measurements of a LTCC delay line.

From these measurements, the multi-technology approach seems suitable to cover the 1250:1 expected delay range over the bandwidth since each of the chosen techniques meets the requirements in its specified delay range. The previous validations point out both the group delay flatness and the necessity to compensate for insertion losses at several levels.

IV. ARCHITECTURE

Table I. indicates the relationship between introduced delay and simulated target distance and the corresponding adopted technologies to get the optimum topology over the entire distance range (0 - 250 m).

Technology	LTCC delay lines				Optical fibers		SAW filters			
Distance (m)	0.2	0.5	1	2	4	8	16	32	64	128
Delay (ns)	1.33	3.34	6.67	13.3	26.7	53.3	107	213	427	853

Table I. Relation between simulated target distances and delays, and selected technologies.

Fig. 6 describes the proposed delay line architecture where the microcontroller already used in the current RTS will pilot the SPDT (Single-Pole-Double-Throw) switches to cover the range from 13 ns to 1.67 μ s with a 1.3 ns step.

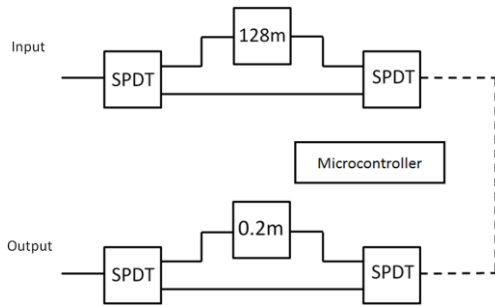

Fig. 6. Delay line architecture.

The following simulations (Fig. 7) show the group delay of the whole structure in different switch configurations.

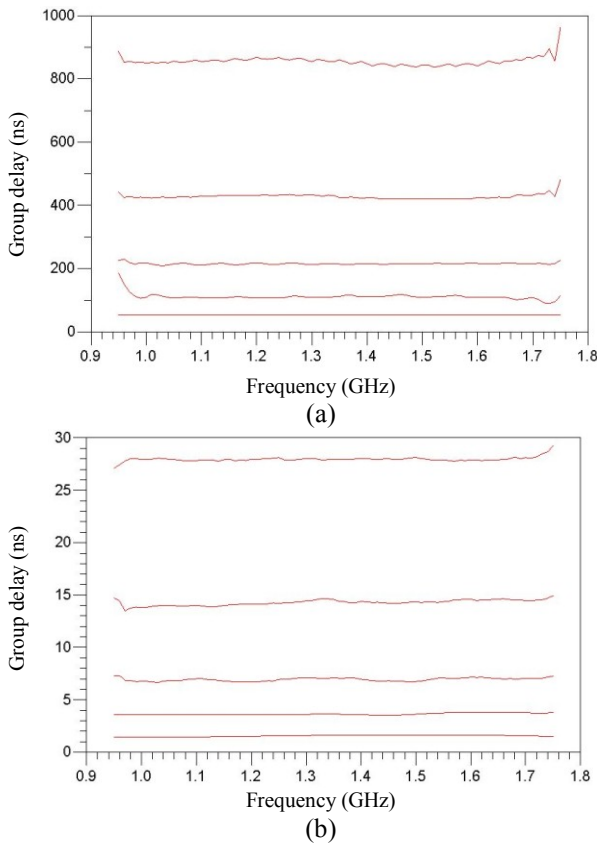

Fig. 7. Group delay simulations of the whole delay line, (a) from 53.3 ns to 853 ns, (b) from 1.33 ns to 26.7 ns.

These simulations take into account i) S-parameters of switches provided by the supplier and ii) measured S-parameters for all the delay sections.

A careful study of these curves shows that SAW filters induce a rise of the group delay at each end of band which slightly reduces the operating band.

V. CONCLUSION

This study shows the possibility to realize a more than 1250:1 tunable delay line. Indeed, by using commercially available components, a small-size and low-cost wideband 800 MHz delay line tunable from 1.3 ns to 1.67 μ s with a 1.3 ns step was designed. The prototype able to simulate finally a distance from 10 m to 250 m with a hybridization of three different technologies is currently under completion. Here, innovation is mostly at a system level and comes from an architecture specifically developed around components, carefully selected according to the criteria of delay, cost, size and losses. The next steps will consist, first, in compensating losses, secondly, in fitting and optimizing the delay line for our RTS, and finally, in validating the RTS with automotive radar sensors in a test bench.

ACKNOWLEDGMENT

The author would like to thank Mr. Stephane Girod from IUT of Brest for PCB implementation.

REFERENCES

- [1] E. Granot, R. Weber, S. Tzadok, G. Gertel, N. Narkiss, « Fibers vs. coax for RF delay line applications », in *IEEE International Conference on Microwaves, Communications, Antennas and Electronics Systems, 2009. COMCAS 2009*, p. 1-2.
- [2] A. A. Shirakawa, « Etude, synthèse et réalisation de filtres Baw pour applications mobiles », PhD thesis, Université de Bordeaux I, 2006.
- [3] W. Sahyoun, « Modélisation et caractérisation linéaire et non linéaire des filtres RF en technologie BAW et CRF et méthode pseudo-temporelle de test industriel », PhD thesis, Université de Grenoble, 2011.
- [4] H. Jiang, R.-M. Xu, « 9.5 GHz 16 lambda G.Delay Line Using Multilayer LTCC », *Prog. Electromagn. Res. Lett.*, vol. 6, p. 175-182, 2009.
- [5] J. Lucas, E. Geron, T. Ditchi, « Using a 1D bandgap metamaterial to build up a delay line », *IET Microwaves, Antennas and Propagation*, vol. 9, p. 151-158, jan. 2015.
- [6] Yi Wang, « Superconducting Coplanar Delay Lines », PhD thesis, University of Birmingham, 2005.
- [7] G. Chaudhary, H. Choi, Y. Joeng, J. Lim, C. D. Kim, « Design of Group Delay Time Controller Based on a Reflective Parallel Resonator », *ETRI J.*, vol. 34, n° 2, p. 210-215, apr. 2012.
- [8] « 1350 MHz SAW Delay Line - M383-1350M1.pdf ». <http://www.microsaw.fi/pdf/saw-delay-line/1350-mhz/M383-1350M1.pdf>.
- [9] « AFBR-1310Z », « AFBR-2310Z ». <http://www.avagotech.com/products/fiber-optic-modules-components/industrial/industrial-control-general-purpose/1300nm>.
- [10] « Fixed Delay Line from ELMEC Technology of America, Inc. » <http://www.elmectech.com/cdm/cdm.html>.