



HAL
open science

Group-nets and strict-group-nets

Goulven Guillou

► **To cite this version:**

Goulven Guillou. Group-nets and strict-group-nets. Petri Net Newsletter, 2004, 67, pp.17-25. hal-01102979

HAL Id: hal-01102979

<https://hal.univ-brest.fr/hal-01102979v1>

Submitted on 13 Jan 2015

HAL is a multi-disciplinary open access archive for the deposit and dissemination of scientific research documents, whether they are published or not. The documents may come from teaching and research institutions in France or abroad, or from public or private research centers.

L'archive ouverte pluridisciplinaire **HAL**, est destinée au dépôt et à la diffusion de documents scientifiques de niveau recherche, publiés ou non, émanant des établissements d'enseignement et de recherche français ou étrangers, des laboratoires publics ou privés.

Group-nets and strict-group-nets

Goulven GUILLOU

EA 2215

Département d'informatique

U.F.R. des sciences et techniques

Université de Bretagne Occidentale

6, av. Le Gorgeu 29200 Brest, FRANCE

Email: goulven.guillou@univ-brest.fr

September 12, 2003

Abstract

By modifying the firing rule of Petri nets, we define strict- \mathbb{Z} -nets and we generalize the latter to strict- G -nets for an arbitrary group G . We show that strict- \mathbb{Z} -nets are an extension of pure Petri nets and we classify strict- G -nets for various groups G with respect to usual classes of Petri nets. In order to cover both strict- \mathbb{Z} -nets and general Petri nets, we add to our nets new arcs with relaxed firing conditions, thus obtaining \mathbb{Z} -nets, and more generally group-nets. We conclude by comparing group-nets with Petri nets.

Keywords: Petri nets.

1 Introduction

Petri nets provide a powerful and convenient framework to describe discrete event systems with concurrency and resource sharing. However, no good characterization of their marking graphs, nor of their languages has emerged. One among the motivations for extending Petri nets is to enlarge the classes of graphs and languages they generate in order to make this characterization easier. However, for most extensions (see for instance [2, 3]), accessibility becomes an undecidable problem, even though boundedness, regularity ... are still decidable. The idea proposed in this paper for extending Petri nets is to use the ordered group \mathbb{Z} in place of the set \mathbb{N} for assigning values to places. Places may take negative values but they are never null. This extension preserves the decidability of the boundedness problem and of the place-boundedness problem [6]. Obviously, one may generalize further by using any group G in place of \mathbb{Z} , yielding what we call strict- G -nets. We will see that the strict- $\mathbb{Z}/3\mathbb{Z}$ -nets are in fact the elementary nets.

We describe strict-group-nets in section 2 and give our first result: the strict- \mathbb{Z} -nets are an extension of the pure Petri nets. We exhibit in section 3 an infinite family of incomparable strict-group-nets (the strict- $\mathbb{Z}/p\mathbb{Z}$ -nets for varying p) and we show various inclusions between strict-group-nets and Petri nets. Group-nets are introduced in section 4, by adding non-conditional arcs to strict-group-nets. We show that \mathbb{Z} -nets extend Petri nets, and we study $\mathbb{Z}/n\mathbb{Z}$ -nets and in particular $\mathbb{Z}/2\mathbb{Z}$ -nets, which are an extension of elementary nets, still synthesizable in polynomial time. The concluding section gives a global classification of group-nets and Petri nets.

2 Strict-group-nets

To begin with, let us recall the basic definitions of Place/Transition nets, called Petri nets in the sequel, and of their generated graphs and languages.

Definition 2.1 (Petri net) A Petri net is a triple $N = (P, T, f)$ where P and T are finite disjoint sets of places and transitions respectively, and $f : P \times T \cup T \times P \rightarrow \mathbb{N}$ is the weight function. A marking of \mathbb{N} is a map $M : P \rightarrow \mathbb{N}$.

The behaviour of a Petri net is completely determined by the *firing rule* which tells that a transition is enabled to fire at a marking if that marking supplies enough resources and which also defines the new marking reached after the transition has fired.

Definition 2.2 (Firing rule) Let $N = (P, T, f)$ be a Petri net and M a marking of N . We say that $t \in T$ is enabled at M if $\forall p \in P, M(p) + f(p, t) \geq 0$ and denote this by $M[t >$. If transition t is enabled at a marking M , then it can be fired and it generates a new marking M' , defined by $\forall p \in P, M'(p) = M(p) - f(p, t) + f(t, p)$. We denote this firing step by $M[t > M'$. A sequence of transitions $u = t_1 t_2 \dots t_n$ is enabled at a marking M_0 if $\exists M_1, \dots, M_n$ such that $M_{i-1}[t_i > M_i$ for all $i = 1, \dots, n$. This firing sequence is denoted $M_0[u > M_n$.

Definition 2.3 (Marked Petri net) A marked Petri net is a quadruple $N = (P, T, f, M_0)$ where (P, T, f) is a Petri net and $M_0 : P \rightarrow \mathbb{N}$ is the initial marking. The set of all markings reachable from M_0 is the smallest set $\mathcal{M}(N)$ of markings such that

1. $M_0 \in \mathcal{M}(N)$
2. If $M \in \mathcal{M}(N)$ and $M[t > M'$ then $M' \in \mathcal{M}(N)$.

Definition 2.4 (Marking graph) The marking graph of a marked Petri net $N = (P, T, f, M_0)$ is the labelled transition system $MG(N) = (\mathcal{M}(N), T, Tr(N))$ where $\mathcal{M}(N)$ is the set of states, T the set of labels and $Tr(N) \subseteq \mathcal{M}(N) \times T \times \mathcal{M}(N)$ the set of labelled transitions defined by $(M, t, M') \in Tr(N) \iff M[t > M'$.

Definition 2.5 (Language of a marked Petri net) The language of a marked Petri net $N = (P, T, f, M_0)$ or equivalently, the language of the marking graph $MG(N)$, is the set of all sequences of transitions enabled at M_0 .

Petri nets have tight connections with the ordered group \mathbb{Z} , hence the use of linear algebra to solve numerous problems like semi-flows, accessibility or synthesis (see for instance [8]). What we suggest now is to modify the firing rule of Petri nets by allowing places of nets to take all values in \mathbb{Z} excepting 0 (the neutral element of the group).

Definition 2.6 (Strict-group-net) Let $(G, +)$ be a (non necessarily abelian) group with at least two elements. We denote by 0 the neutral element. A strict-group-net is a quadruple (P, T, f, M_0) where P and T are finite disjoint sets (the set of places and the set of transitions, respectively), $f : P \times T \rightarrow G$ is the weight function and $M_0 : P \rightarrow G \setminus \{0\}$ is the initial marking. More generally, all maps from P to $G \setminus \{0\}$ are called markings.

Figure 1 shows a strict- $\mathbb{Z}/3\mathbb{Z}$ -net. Following the graphical notation of Petri nets, places are denoted by circles, and transitions by rectangular (black) boxes. Notice that, dislike Petri nets, strict-group-net graphs have non oriented arcs. An arc between a place p and a transition t is labelled with the weight $f(p, t)$. Like in Petri nets, the arcs labelled with 0 are omitted. The initial marking is defined by the respective values written in the places. Thus if $M_0(p) = a \in G \setminus \{0\}$, a appears in the circle representing p . Let us adapt now the firing rule.

Definition 2.7 (Firing rule for strict-group-nets) Let $N = (P, T, f, M_0)$ be a strict-group-net. A transition $t \in T$ is enabled to fire at a marking M if $\forall p \in P, M(p) + f(p, t) \neq 0$. In this case, the new marking M' reached after firing t is defined by $\forall p \in P, M'(p) = M(p) + f(p, t)$. We denote this step by $M[t > M'$.

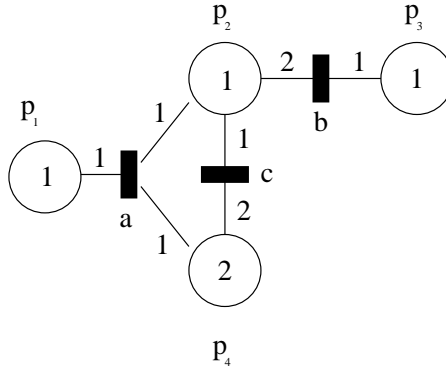

Figure 1: A strict- $\mathbb{Z}/3\mathbb{Z}$ -net

We keep the usual notations for sequences of steps, reachable markings, marking graphs and languages of nets. We consider a strong equivalence on nets, as follows.

Definition 2.8 (Equivalence between nets) *Two nets (either Petri net or strict-group-net) are equivalent if their marking graphs are isomorphic.*

Example: Let $(G, +)$ be a group and $N = (P, T, f, M_0)$ a strict-group-net. Then $N' = (P, T, -f, -M_0)$ is equivalent to N .

At first sight, Petri nets and strict- \mathbb{Z} -nets are quite similar although the notion of resource is lost in the latter. The following theorem shows that any pure Petri net may be simulated by a strict- \mathbb{Z} -net with a larger set of places.

Theorem 2.1 *The strict- \mathbb{Z} -nets are an extension of the pure Petri nets.*

proof Let $N = (P, T, f, M_0)$ be a pure marked Petri net. Let p be a place and t a transition. If the value in p is strictly lower than $f(p, t)$, then t cannot be fired, hence the idea is to replace p by $f(p, t)$ places with respective initial values $M_0(p) + 1, M_0(p) + 2, \dots, M_0(p) + f(p, t)$ whenever $f(p, t) > 0$. Actually, the needed number of copies of p is $n_p = \max_{t \in T} \{f(p, t)\}$. If $n_p > 0$, construct n_p places p_1, p_2, \dots, p_{n_p} marked respectively by $M_0(p) + 1, M_0(p) + 2, \dots, M_0(p) + n_p$. Let P' be the set of places constructed in this way from the places in P . Let $f' : P' \times T \rightarrow \mathbb{Z}$ be the weight function defined by $f'(p_i, t) = -f(p, t) + f(t, p)$. Consider the strict- \mathbb{Z} -net $N' = (P', T, f', M'_0)$ where $\forall p_i \in P', M'_0(p_i) = M_0(p) + i$ with $1 \leq i \leq n_p$. As this correspondence between the markings of N and N' is preserved by transition firing, the nets N and N' are actually equivalent. \diamond

Obviously, all strict- G -nets when G is a finite group have finite marking graphs, hence they cannot be an extension of pure Petri nets. Let us compare now strict- \mathbb{Z} -nets and general Petri nets. Figure 2 shows a Petri net with a self loop and its marking graph.



Figure 2: A Petri net with no equivalent strict-group-net

Let us suppose that some strict- G -net has a marking graph isomorphic to the above, thus the action of t is the action of the neutral element in $\mathbb{Z}^{|P|}$. The transition t must be enabled after u , but this is not the case in the Petri net. Therefore the strict- \mathbb{Z} -nets cannot be an extension of the Petri nets. On the other hand, the inclusion of the pure Petri nets into the strict- \mathbb{Z} -nets is strict. In order to see this, consider the strict- \mathbb{Z} -net shown in figure 3.

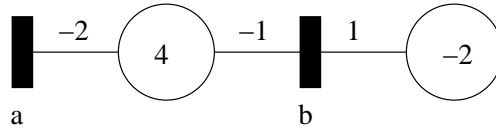

Figure 3: A strict- \mathbb{Z} -net with no equivalent Petri net

The language of this net is the set of all prefixes of words in $ba^* + aba^*$. This is not a Petri net language. Indeed, as a may be fired an arbitrary number of times after a single firing of b , it must be the case that $f(p, a) \leq f(a, p)$ for every place p in a Petri net with a language including the considered language. But a is enabled at the initial marking, and aa does not belong to the considered language, showing the contradiction.

Finally notice that coverability trees may be defined for strict- \mathbb{Z} -nets (in a weaker form than usual) and may be used to decide on boundedness and place-boundedness (for details, see [6]).

3 Strict- $\mathbb{Z}/p\mathbb{Z}$ -nets

Next, we explore the strict- $\mathbb{Z}/p\mathbb{Z}$ -nets with p prime. For this purpose, we need recalling a few notions from studies on generalized net synthesis.

Definition 3.1 (Type of nets) A type of nets is a transition system $\tau = (Q, E, T)$ where Q and E are disjoint sets (respectively, the set of states and the set of events) and $T \subseteq Q \times E \times Q$ (T is the set of transitions).

In the sequel, we work with deterministic types of nets, in other words, if $(q, a, q') \in T \wedge (q, a, q'') \in T$ then $q' = q''$.

Definition 3.2 (Nets of type τ and their markings) A net of type $\tau = (Q, E, T)$ is a structure $N = (P, E', f)$ where P and E' are disjoint sets (of respectively places and events) and f is a map from $P \times E'$ to E (called the flow map). A marking of N is a map from P to Q .

Definition 3.3 (Firing rule for nets of type τ) Let $N = (P, E', f)$ be a net of type $\tau = (Q, E, T)$ and let M be a marking of N . An event $e \in E'$ may be fired at M , resulting in a transition $M[e > M']$, if and only if there exists for all $p \in P$, $(M(p), f(p, e), M'(p))$ in T .

Now, let us focus our attention on the strict- $\mathbb{Z}/p\mathbb{Z}$ -nets (with p prime). The type of these nets is the Cayley graph of $\mathbb{Z}/p\mathbb{Z}$ restricted on the nodes with non-null values. Let $\mathcal{C}(\mathbb{Z}/p\mathbb{Z})$ denote this graph.

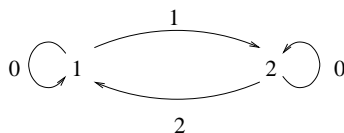

Figure 4: $\mathcal{C}(\mathbb{Z}/3\mathbb{Z})$

It therefore turns out that the strict- $\mathbb{Z}/3\mathbb{Z}$ -nets are the elementary nets, since both families of nets have isomorphic types (see [7]).

Let us state two more results.

Proposition 3.1 *The pure Petri nets and the strict- $\mathbb{Z}/p\mathbb{Z}$ -nets are an extension of the strict- $\mathbb{Z}/3\mathbb{Z}$ -nets for $p \geq 3$.*

Proposition 3.2 *For all $p, q > 3$, the strict- $\mathbb{Z}/p\mathbb{Z}$ -nets and the strict- $\mathbb{Z}/q\mathbb{Z}$ -nets are incomparable if $p \neq q$, and the strict- $\mathbb{Z}/p\mathbb{Z}$ -nets and the strict- \mathbb{Z} -nets are incomparable for $p > 3$.*

In order to establish the first proposition, we rely on the following result from [1].

Theorem 3.1 *If τ_1 is isomorphic to the marking graph of a net of type τ_2 , then the nets of type τ_1 are included in the nets of type τ_2*

proof of proposition 3.1 First, the marking graph of the Petri net

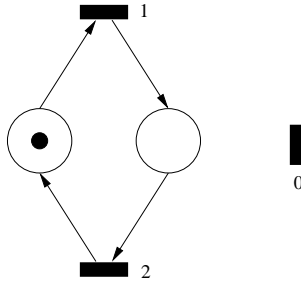

is isomorphic to the type of the strict- $\mathbb{Z}/3\mathbb{Z}$ -nets.

Second, the type $\mathcal{C}(\mathbb{Z}/3\mathbb{Z})$ of the strict- $\mathbb{Z}/3\mathbb{Z}$ -nets is isomorphic to the marking graph of the strict- $\mathbb{Z}/p\mathbb{Z}$ -net:

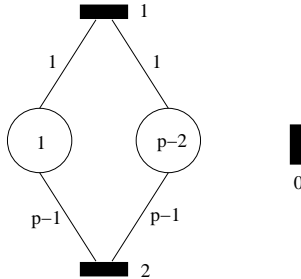

◇

Let us remark that the pure Petri nets and, for $p > 3$, the strict- $\mathbb{Z}/p\mathbb{Z}$ -nets are proper extensions of the strict- $\mathbb{Z}/3\mathbb{Z}$ -nets.

Theorem 3.1 may be used to show that a family of nets extends another one, but it does not help to show the converse, which is actually needed for proving proposition 3.2. In order to establish this proposition, let us bring back more material on generalized net synthesis.

Definition 3.4 (Transition system morphism) *Let (Q_1, E_1, T_1) and (Q_2, E_2, T_2) be two transition systems. A transition system morphism $(\sigma, \tau) : (Q_1, E_1, T_1) \rightarrow (Q_2, E_2, T_2)$ is a pair of maps $\sigma : Q_1 \rightarrow Q_2$ and $\tau : E_1 \rightarrow E_2$ such that $q \xrightarrow{e} q' \in T_1 \implies \sigma(q) \xrightarrow{\tau(e)} \sigma(q') \in T_2$.*

Definition 3.5 (Region of a transition system) *Let (Q_1, E_1, T_1) be a transition system and $\tau = (Q_2, E_2, T_2)$ a type. A region of the transition system is a morphism (σ, ρ) from (Q_1, E_1, T_1) to (Q_2, E_2, T_2) .*

Regions of labelled graphs have been introduced in [4] and [5] where they served (among other) to characterize graphs isomorphic to marking graphs of elementary nets. Crucial to this characterization is the property of states separation that we recall now.

Let $Gr = (S, T, A, l)$ be a labelled graph where S is the set of nodes or states, T is the set of arcs, A is the set of actions and $l : T \rightarrow A$ is the labeling function. Two nodes $s, s' \in S$ are *separated* by a region (σ, ρ) of Gr if $\sigma(s) \neq \sigma(s')$. We shall use the following fact: if two nodes in a given graph Gr cannot be separated by any region $(\sigma, \rho) : Gr \rightarrow \mathcal{C}(\mathbb{Z}/q\mathbb{Z})$, then no strict- $\mathbb{Z}/q\mathbb{Z}$ -net can exist with a marking graph isomorphic to the considered graph. This is a direct application of the general results in [1].

proof of proposition 3.2 Assuming $p > 3$, let $Gr = \mathcal{C}(\mathbb{Z}/p\mathbb{Z})$. Clearly, Gr is isomorphic to the marking graph of a strict- $\mathbb{Z}/p\mathbb{Z}$ -net. Suppose for a contradiction that Gr is isomorphic to the marking graph of some strict- $\mathbb{Z}/q\mathbb{Z}$ -net, with $q > 3$ and $p \neq q$. Then, there should exist some morphism of transition systems $(\sigma, \rho) : \mathcal{C}(\mathbb{Z}/p\mathbb{Z}) \rightarrow \mathcal{C}(\mathbb{Z}/q\mathbb{Z})$ such that $\sigma(1) \neq \sigma(2)$. By definition of morphisms, one must have $\sigma(1 + 2) = \sigma(1) + \rho(2)$ in $\mathbb{Z}/q\mathbb{Z}$ (as $q > 3$, $\sigma(1 + 2)$ is defined), hence $\sigma(1 + 2) = (\sigma(1) + 2\rho(1)) \bmod q$, hence $\rho(2) = 2\rho(1) \bmod q$. One must have also $\sigma(p + 1) = (\sigma(1) + (p-2)\rho(1) + \rho(2)) \bmod q$ hence, as $\rho(2) = 2\rho(1)$ in $\mathbb{Z}/q\mathbb{Z}$, $\sigma(p+1) = (\sigma(1) + p\rho(1)) \bmod q$ and, as $\sigma(p + 1) = \sigma(1)$ and p, q are prime, it follows that $\rho(1) = 0$. As a consequence, $\sigma(1) = \sigma(2)$, showing that the strict- $\mathbb{Z}/p\mathbb{Z}$ -nets and the strict- $\mathbb{Z}/q\mathbb{Z}$ -nets are two incomparable families of nets. The above argument, reproduced in \mathbb{Z} in place of $\mathbb{Z}/q\mathbb{Z}$, gives the same equations without *mod.q* and shows also that the strict- $\mathbb{Z}/p\mathbb{Z}$ -nets are not a restriction of the strict- \mathbb{Z} -nets. Seeing that strict- \mathbb{Z} -nets may have infinite marking graphs, the second part of the proposition follows. \diamond

To conclude this section, we present a first classification, when the strict- $\mathbb{Z}/2\mathbb{Z}$ -nets play a particular role: the marking graph of a strict- $\mathbb{Z}/2\mathbb{Z}$ -net has exactly one state, thus, if the net has a single transition, it is the terminal object in the category of transition systems.

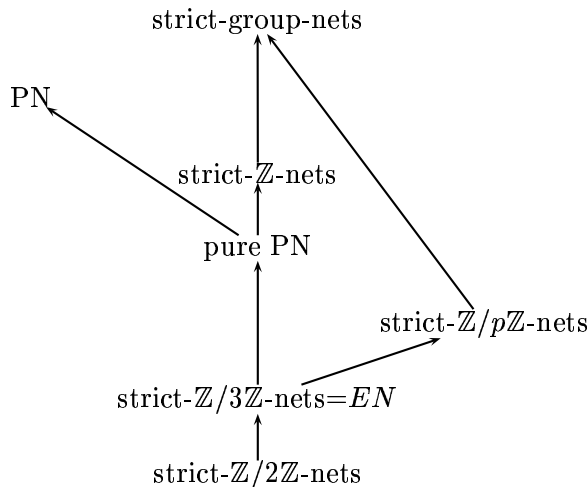

Figure 5: A first classification

In the above figure, all inclusions are strict, and whenever no directed path exists between two nodes, the corresponding families of nets are incomparable.

4 Group-nets

The fact that, for no group G , the strict- G -nets are an extension of the Petri nets, motivates a common extension of Petri nets and strict- \mathbb{Z} -nets. For this purpose, we suggest to add to our nets non-conditional arcs, that allow to fire a transition even though the place to which the arc connects the transition may attain the (up to now forbidden) value 0.

Definition 4.1 (Group-net) Let G be a group. A group-net is a quadruple $N = (P, T, f, M_0)$ where P is a finite set of places, T is a finite set of transitions (disjoint from P) and f is a map from $P \times T$ to $\{0, 1\} \times G$. A flow arc is a pair $(p, t) \in \text{dom}(f)$. The arc (p, t) is said to be conditional if $\pi_1(f(p, t)) = 0$, unconditional if $\pi_1(f(p, t)) = 1$. We denote by $M_0 : P \rightarrow G$ the initial marking of a net.

Definition 4.2 (Firing rule for group-nets) Let $N = (P, T, f, M_0)$ be a group-net over G , $t \in T$ is enabled to fire at $M \in G^{|P|}$ if for all p in P , $\pi_1(f(p, t)) = 0 \implies M(p) + \pi_2(f(p, t)) \neq 0$. In case where t is enabled to fire at M , the firing of t produces a new marking M' , defined by $M'(p) = M(p) + \pi_2(f(p, t))$ for every place $p \in P$.

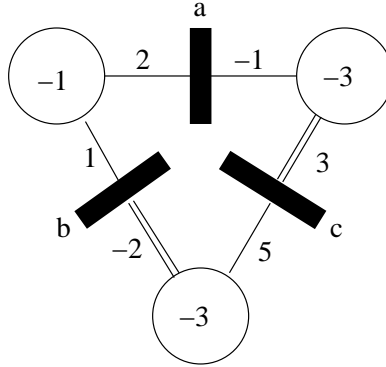

Figure 6: A \mathbb{Z} -net

A typical \mathbb{Z} -net is shown in figure 6. By convention, non-conditional arcs are represented by double lines. In this example, b cannot be fired, but a or c may be fired.

The following is the main result of the section.

Theorem 4.1 *The \mathbb{Z} -nets are an extension of the Petri nets.*

proof Let $N = (P, T, f, M_0)$ be a marked Petri net. For any $p \in P$, let $E_p = \cup_{t \in T} \{M_0(p) - f(t, p) + 1, M_0(p) - f(t, p) + 2, \dots, M_0(p) - f(t, p) + f(p, t)\}$. For any $p \in P$ and for each $i \in E_p$, define one place p_i . Let P' be the set of all places defined thus for p ranging over P . The initial value of each place $p_i \in P'$ is the subscripted i . Let $f' : P' \times T \rightarrow \mathbb{Z}$ be the weight function defined as follows: for any $p \in P$ and for each $i \in E_p$, let $f'(p_\alpha, t) = (0, -f(p, t) + f(t, p))$ if $M_0(p) - f(t, p) + 1 \leq \alpha \leq M_0(p) - f(t, p) + f(p, t)$ and $f'(p_\alpha, t) = (1, -f(p, t) + f(t, p))$ otherwise. It may be checked that $N' = (P', T, f', M'_0)$ has a marking graph isomorphic to the marking graph of N . \diamond

In view of the example from figure 3, the above inclusion is strict, because the \mathbb{Z} -nets extend the strict- \mathbb{Z} -nets.

Note that one may still define coverability trees for \mathbb{Z} -nets and use them to decide on boundedness and place-boundedness problem (for details, see [6]).

Many extensions of Petri nets are Turing-powerful, e.g. Petri nets with inhibitory arcs. It is worth noting that this is not the case with \mathbb{Z} -nets. Figure 7 shows an inhibitor net which cannot be represented by a \mathbb{Z} -net.

On the other hand, figure 3 shows a \mathbb{Z} -net with no equivalent inhibitory net. This is rather reassuring, since it leaves open the question of deciding on accessibility in \mathbb{Z} -nets.

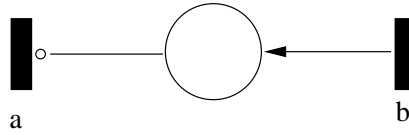

Figure 7: An inhibitor net with no equivalent \mathbb{Z} -net

5 $\mathbb{Z}/n\mathbb{Z}$ -nets

$\mathbb{Z}/2\mathbb{Z}$ -nets play a particular role. On the one hand, the type of flip-flop nets [9] is isomorphic to the marking graph of a $\mathbb{Z}/2\mathbb{Z}$ -net, thus the $\mathbb{Z}/2\mathbb{Z}$ -nets extend the elementary nets. We have shown in [7] that the synthesis of $\mathbb{Z}/2\mathbb{Z}$ -nets takes polynomial time. On the other hand, the type of the $\mathbb{Z}/2\mathbb{Z}$ -nets, shown in the following figure 8

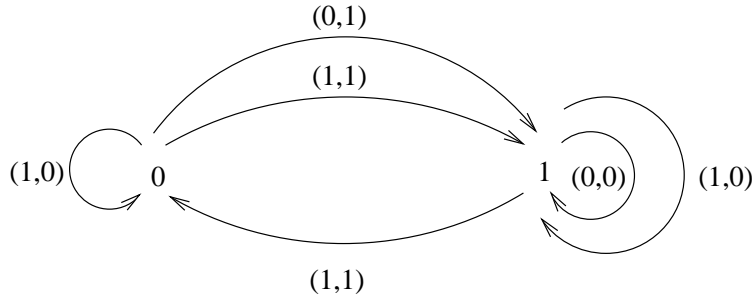

Figure 8: The type of the $\mathbb{Z}/2\mathbb{Z}$ -nets

is the most general type of nets with binary places. Indeed, it provides two events that do not modify place contents (one is always enabled and the other is not), and two events that modify place contents (one is always enabled and the other is not). Hence, the $\mathbb{Z}/2\mathbb{Z}$ -nets are the largest family of nets with binary places, and they extend the one-safe Petri nets.

More generally, the $\mathbb{Z}/(n+1)\mathbb{Z}$ -nets extend the n -safe Petri nets. Indeed, if we reproduce the construction in the proof of theorem 4.1 modulo $(n+1)$, we obtain from an n -safe Petri net an equivalent $\mathbb{Z}/(n+1)\mathbb{Z}$ -net. This inclusion is strict, because it is easy to construct a $\mathbb{Z}/(n+1)\mathbb{Z}$ -net with a cyclic behaviour of order $(n+1)$.

6 Conclusion

In this paper we have introduced strict-group-nets and group-nets. We compared these nets and subclasses thereof (strict- $\mathbb{Z}/p\mathbb{Z}$ -nets, strict- \mathbb{Z} -nets or \mathbb{Z} -nets), with Petri nets and their subclasses. For instance, the strict- \mathbb{Z} -nets are a strict extension of the pure Petri nets. These comparisons are summarized in figure 9 where we have added the $\{0\}$ -nets (as $\{0\}$ is the trivial group, these are the strict- $\mathbb{Z}/2\mathbb{Z}$ -nets). In the figure, all inclusions are strict and whenever there is no directed path between two nodes, the corresponding families of nets are incomparable, except for the $\mathbb{Z}/(n+1)\mathbb{Z}$ -nets and the $\mathbb{Z}/p\mathbb{Z}$ -nets when p divides $(n+1)$.

References

- [1] E. Badouel and P. Darondeau. Theory of regions. In *Lectures on Petri Nets I: Basic Models*, volume 1491 of *Lecture Notes in Computer Science*, pages 529–586. Springer, 1999.

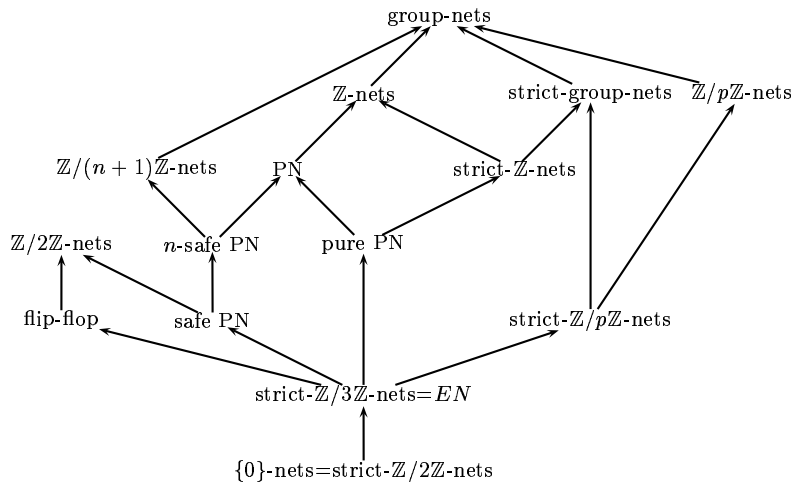

Figure 9: Final classification

- [2] C. Dufourd, A. Finkel, and Ph. Schnoebelen. Reset nets between decidability and undecidability. In *Proceedings of 25th ICALP'98*, volume 1443, pages 103–115. LNCS, Springer, 1998.
- [3] Catherine Dufourd. *Réseaux de Petri avec Reset/Transfert: Décidabilité et Indécidabilité*. PhD thesis, ENS Cachan, 1998.
- [4] A. Ehrenfeucht and G. Rozenberg. Partial 2-structures; part i: basic notions and the representation problem. *Acta Informatica*, 27:315–342, 1990.
- [5] A. Ehrenfeucht and G. Rozenberg. Partial 2-structures; part ii: State spaces of concurrent systems. *Acta Informatica*, 27:343–368, 1990.
- [6] Goulven Guillou. Group-nets et strict-group-nets. Technical report, EA2215, 2003. available on <http://fastnet.univ-brest.fr/~gire/InFo/publications.html>.
- [7] Goulven Guillou. Synthèse des $\mathbb{Z}/2\mathbb{Z}$ -nets. Technical report, EA2215, 2003. available on <http://fastnet.univ-brest.fr/~gire/InFo/publications.html>.
- [8] Christophe Reutenauer. *Aspects mathématiques des réseaux de Petri*. Masson.
- [9] Vincent Schmitt. Flip-flop nets. In *Proceedings of Stacs 96*, pages 517–528. Lectures Notes in Computer Science, 1996.