



HAL
open science

Microstrip line modelling in the presence of interfering metal strips according to their orientation.

Thierry Le Gougec, Pierre-Marie Martin

► **To cite this version:**

Thierry Le Gougec, Pierre-Marie Martin. Microstrip line modelling in the presence of interfering metal strips according to their orientation.. Signal and Power Integrity (SPI), 2012 IEEE 16th Workshop on, May 2012, Sorrento, Italy. pp.121 - 124, 10.1109/SaPIW.2012.6222925 . hal-00716054

HAL Id: hal-00716054

<https://hal.univ-brest.fr/hal-00716054>

Submitted on 9 Jul 2012

HAL is a multi-disciplinary open access archive for the deposit and dissemination of scientific research documents, whether they are published or not. The documents may come from teaching and research institutions in France or abroad, or from public or private research centers.

L'archive ouverte pluridisciplinaire **HAL**, est destinée au dépôt et à la diffusion de documents scientifiques de niveau recherche, publiés ou non, émanant des établissements d'enseignement et de recherche français ou étrangers, des laboratoires publics ou privés.

Microstrip line modelling in the presence of interfering metal strips according to their orientation.

Thierry Le Gougec, Pierre-Marie Martin
Université de Brest ; CNRS, UMR 6285 Lab-STICC,
6 avenue Victor Le Gorgeu, CS 93837, 29238 Brest cedex 3, France
Thierry.legougec@univ-brest.fr ; Pierre-Marie.Martin@univ-brest.fr

Abstract

In the context of PCB technology, this paper deals with the measurement and simulation of propagation from a microstrip line disturbed by a metal ribbon placed just above it. We investigate the influence of the angular orientation of the interfering strip and we highlight the presence of disturbances on transmission S-parameters. Lastly, we propose a model of these ribbon orientation effects, which is validated by the experimental results.

Introduction

Higher integration densities and an increase in the number of metal layers in PCB structures as well as the use of new concepts such as “System in Package” (SiP) or “System on Package” (SoP) [1], all cause a significant rise in the possible interactions between various interconnects or between interconnects and power/ground grids. Furthermore, an increase in clock frequencies makes these interactions more problematic for signal integrity.

Effects induced by perpendicular metal grids on the characteristics of transmission lines or coupled lines in a multilayered architecture were highlighted in [2] and [3].

In this communication, our investigations aim at modeling the impact by metal disturbances whatever their orientation on signal propagation in microstrip line. The context of this study is multilayered PCB circuits.

Disturbing effect of one parasitic strip

Fig. 1 shows a photograph of the measurement structure under consideration. This device consists of a main 50 Ω microstrip copper line measuring length $L = 60$ mm and width $W = 1400$ μ m placed over a FR4-type substrate $\epsilon_R=3.6$ whose thickness is $H_{sub}=780$ μ m and loss tangent $\tan(\delta)=0.02$. This line is disrupted by a metal ribbon realized on a similar substrate and placed at the upper level. The perturbed line can make an angle with the main line of $\theta = 0^\circ, 30, 60$ or 90° .

This microstrip structure allows us to model the line behaviour in a multilayered PCB environment. We analyzed the impact on transmission by length (L_p) and width (W_p) of the disturbing metal strip and effect of its angle orientation θ with respect to the line. We also considered floating parasitical ribbons and the case of ground (of main line) connected interfering strips. The S-parameters measurements were made with a HP8720 network analyser over the 0 - 10 GHz frequency band after a simple SOLT calibration.

Fig. 2 shows both S_{11} and S_{21} (reflection and transmission) coefficients of the MTL line in the presence of a parasitic floating metal strip of length $L_p=40$ mm, width $W_p=1400$ μ m

for three θ angles equal to: $30^\circ, 60^\circ$ and 90° . The interference line is separated to the MTL line by a substrate 780 μ m thick. In Fig. 2, we also present the results of the reference MTL alone. About the transmission (Fig2-a), we note the occurrence of several transmission zeroes in the frequency bandpass: 0 - 10 GHz, which can be very harmful in signal transmissions [2]. Note that the disturbing line orientation modifies the frequencies at which transmission zeroes occur. For example, we notice a 200 MHz variation of the transmission zero occurrence frequency situated around 4 GHz when the orientation angle varies between 30° and 90° .

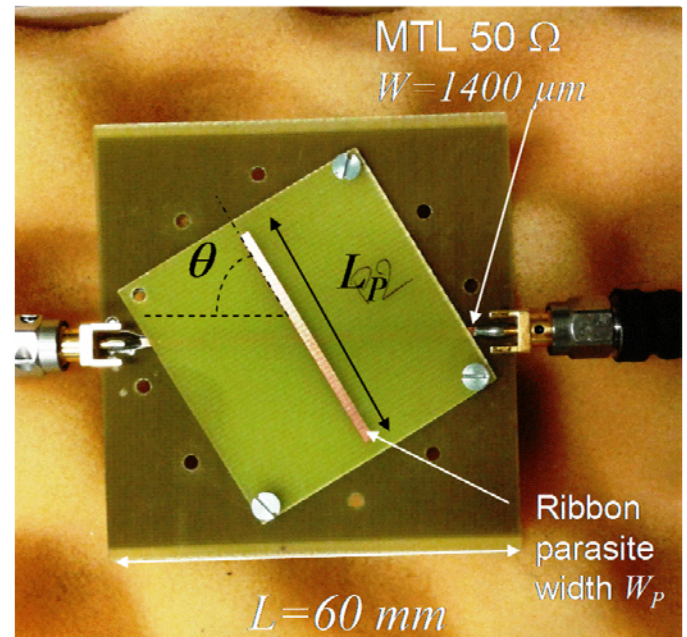

Fig. 1: Top view of the structure under test– Microstrip line (MTL) in the presence of a disturbing floating metal strip.

The S_{11} reflection (Fig. 2-b) doesn't add more useful information than the S_{21} and it is just given here as an indication.

Circuit model

Based on the previous studies we propose the equivalent circuit model presented in Fig. 3. This model is based on a lumped electric and magnetic coupling between the main microstrip line and the disruptive line. The angle orientation effects result in two inductive K_L and capacitive K_C coupling coefficients.

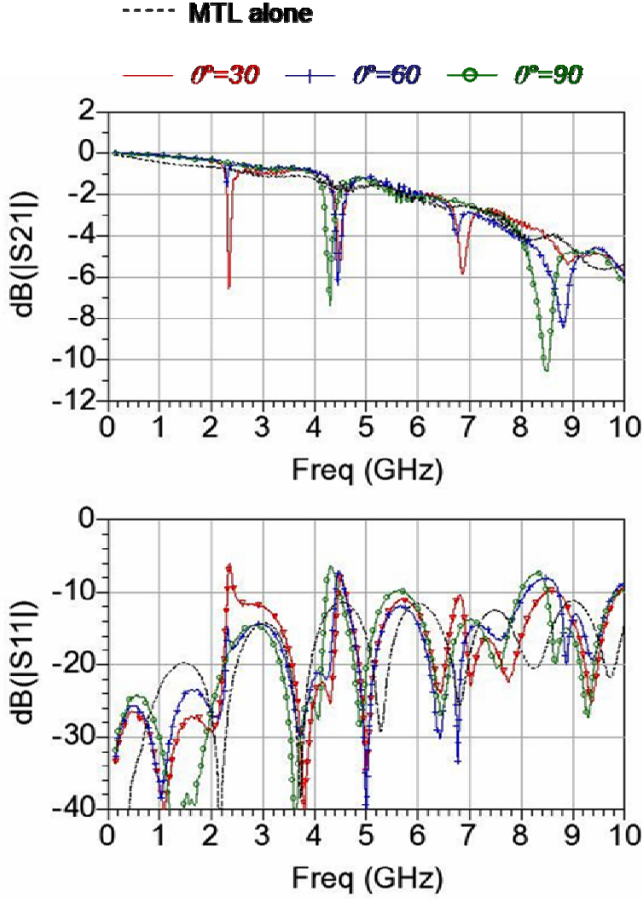

Fig. 2: Measured S parameters for $\theta = 30^\circ$, 60° , and 90° in case of a floating interfering strip.

These coefficients can be calculated by Q3D extractor software to ANSYSTM and their evolutions with θ are presented in Fig. 4. The lumped coupling capacitance Γ and the lumped coupling inductance M are related to K_C and K_L by the following expressions.

$$\begin{aligned} \Gamma &= K_C \sqrt{C_1 C_2} \\ M &= K_L \sqrt{L_1 L_2} \end{aligned} \quad (1)$$

Where C_1 and C_2 represent the capacitances of the main microstrip line and the interfering ribbon respectively; L_1 and L_2 represent the inductances of the MTL and the disturbing conductor in the coupling zone.

The capacitive coupling coefficient K_C varies significantly for angles θ inferior to 45° . Beyond $\theta = 45^\circ$, K_C coefficient varies only slightly with increasing angle θ . Regarding the inductive coupling coefficient K_L , we observe a quasi-linear variation. K_L value is maximum when the interfering strip is aligned with the line, and of course, K_L tends towards zero when the main line and disruptive conductor are perpendicular.

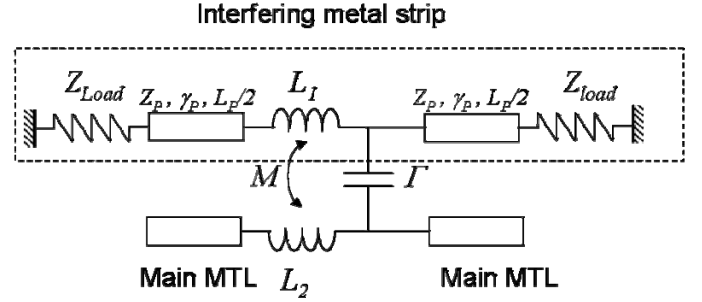

Fig. 3: Equivalent circuit model of a microstrip transmission line (MTL) in presence of an interfering metal strip.

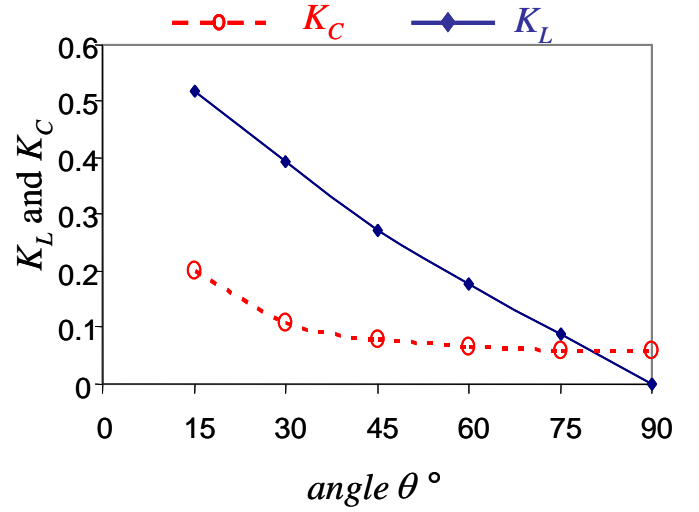

Fig. 4: K_C and K_L evolution with the orientation angle in the case of 40 mm long interfering floating strip

In the model, the influence of the length and the width of an interfering strip are mainly taken into account in modelling transmission line of the disturbing conductor. Finally the impedance Z_{load} can account for the floating character ($Z_{load} \approx \infty$) or connected to MTL ground ($Z_{load} \approx 0$) of the parasite line.

To validate our method, we compared the simulation and measurement results for several types of disruptive metal strips (different widths W_p and lengths L_p) and also for different orientation angle values. For example, Fig. 5 shows comparisons on S_{21} transmission coefficient between the circuit model and the measurements of an interfering floating metal ribbon $L_p=40$ mm long, $W_p=1400$ μm wide and for $\theta = 60^\circ$. There is a good agreement between measurements and circuit modeling simulations. We have also verified our modelling by comparing circuit simulation with HFSS EM results in both cases floating disruptive metal strip and shorted one. These results are presented in Fig.6 and Fig. 7. Here again, EM and circuits modelling results concur closely, which validate our circuit approach.

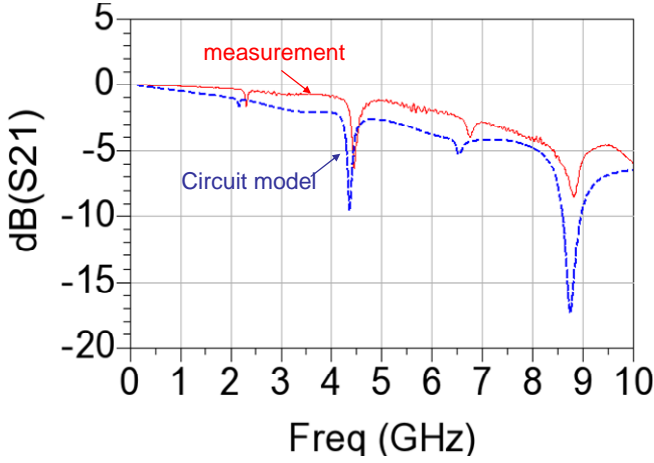

Fig. 5: Measured and modeled S_{21} transmission parameter for $\theta = 60^\circ$ and $L_P = 40$ mm (floating disruptive metal strip).

So, this electrical circuit approach can be used to consider and to predict the impact by diverse disturbing metallic lines placed above main lines in multilayered PCB structures.

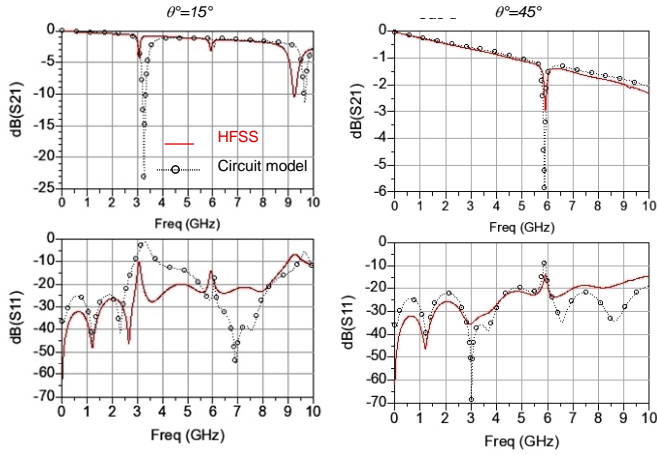

Fig. 6: S parameters of MTL in presence of interfering floating strip forming an angle $\theta = 15^\circ$ or $\theta = 45^\circ$.

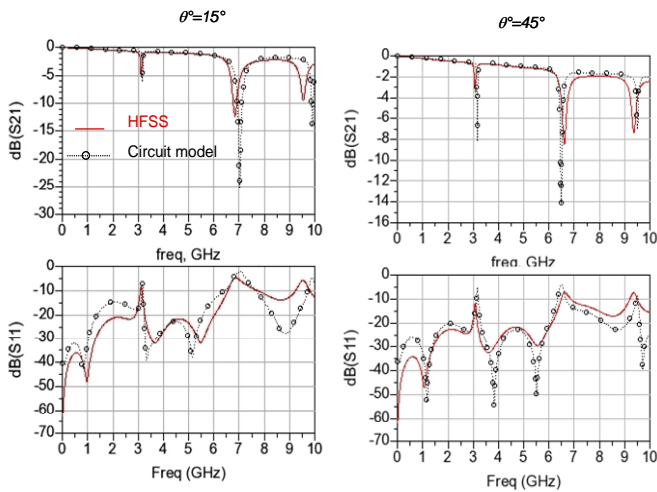

Fig. 7: S parameters of MTL in presence of interfering strip connected to the MTL ground forming an angle $\theta = 15^\circ$ or $\theta = 45^\circ$.

The two approaches (EM simulation and circuit modelling) are coherent in both cases, floating parasitic strip or connected to the MTL ground, which validate again our circuit model.

We extend this circuit approach to the case of a microstrip transmission line in presence of metal parasitic grids.

Circuit model of MTL in presence of an arbitrarily oriented metal grid.

Fig. 8 presents an example of the structures considered in this section. We consider a 40 mm long metal grid composed of 10 parallel strips. These grids can be oriented in relation with the microstrip line. We also have considered the cases of a floating grid and connected to the MTL ground. This study was realized using both EM simulations and measurements.

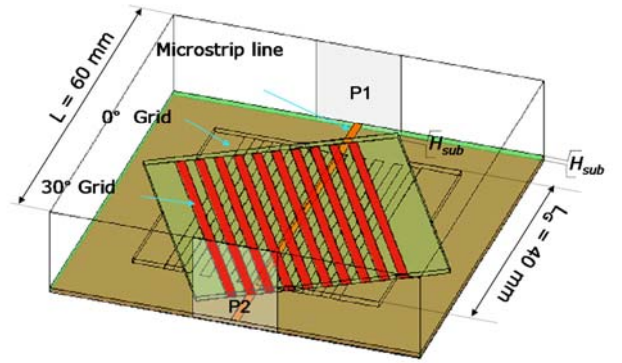

Fig.8: Microstrip line in presence of a 10 strip metal grid.

To model these structures by a circuit, we have considered each strip as independent. The grid can be modelled by a succession of elementary cells such as those presented in the previous section. Fig. 9 presents the proposed equivalent circuit model of a microstrip line disrupted by a 10 strip metal grid.

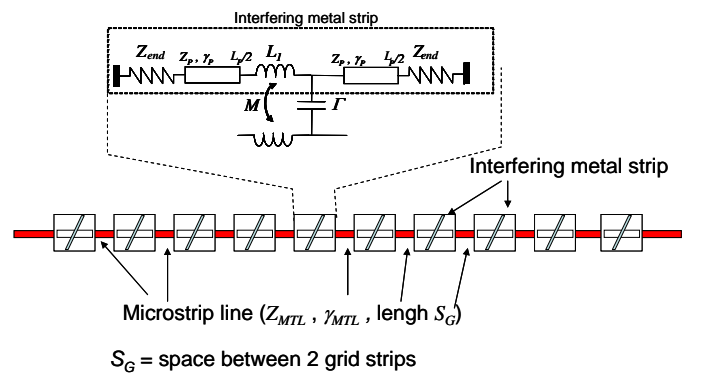

Fig. 9: Circuit model of a MTL in presence of a 10 strip metal grid.

To validate this circuit approach, we have considered a 10 strip metal grid $W_G = 1.4$ mm wide, $S_G = 1.4$ mm spaced and graved on FR4 substrate (thickness $H_{sub} = 780$ μ m, relativity permittivity $\epsilon_R = 3.6$ and loss tangent $\tan(\delta) = 0.02$). The floating grid is $L_G = 40$ mm long and can be oriented of 0° , 30° , 60° or 90° in relation with the microstrip line.

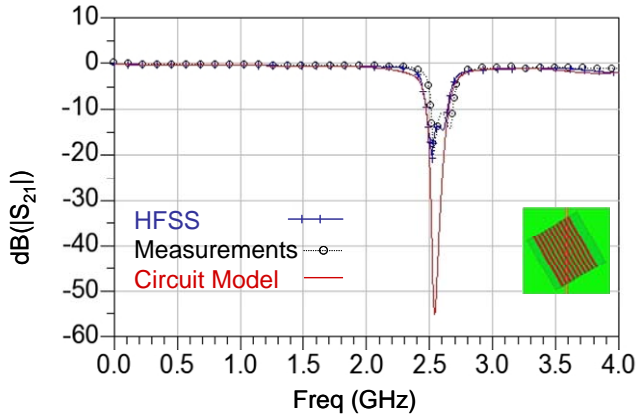

Fig 10-a : grid oriented at 30°

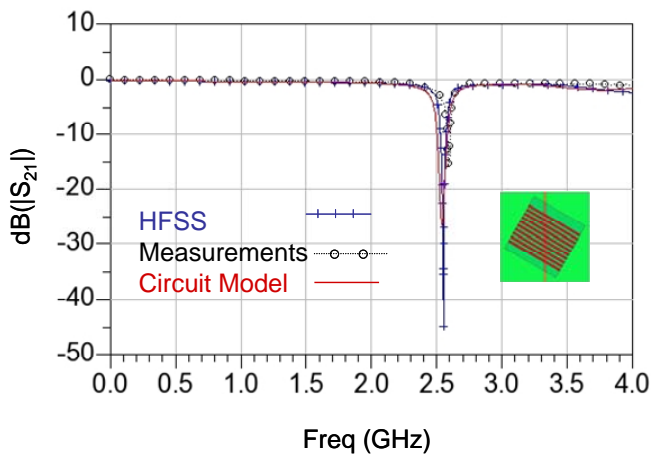

Fig 10-b : grid oriented at 60°

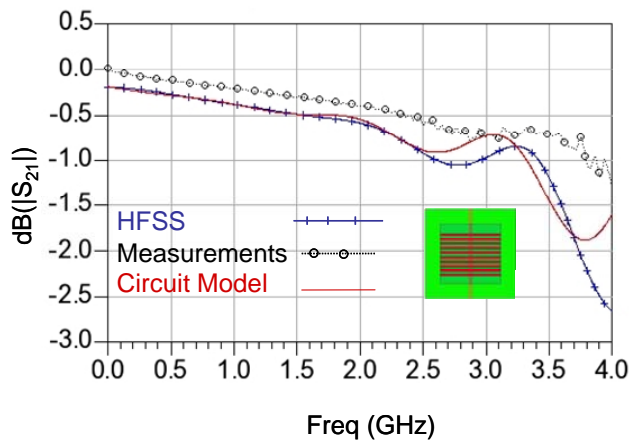

Fig 10-c : grid oriented at 90°

Fig. 10: S_{21} transmission parameter of a MTL in presence of floating interfering metal Grid.

In Fig. 10, we present the S_{21} transmission parameters comparison in the 0-4 GHz frequency band, between the measurements, the electromagnetic simulations and the circuit model results in the cases of a floating grid for 30°, 60° and 90° orientations. We note the presence of a transmission zero around 2.5 GHz for both cases $\theta=30^\circ$ and $\theta=60^\circ$, which can connect with the length of the grid as we showed it in the

previous paragraph. All results concur, which validate first the independence of grid strip and also the circuit model which reflect the grid influence.

Conclusion

In this study, we presented the impact on the propagation characteristics of the orientation angle between an interfering metal strip and a microstrip transmission line. We showed the role of these parasitic lines on the frequencies at which transmission zeroes occur and we proposed a circuit model of these behaviours. We also studied the impact by metal grids on a transmission line in a multilayered PCB environment. We have proposed a simple circuit model which is coherent with measurements and EM simulations.

References

- T. SUDO, and al "Electromagnetic Interference (EMI) of System-on-Package (SOP)" IEEE trans on Advanced Packaging Vol. 27, N°. 2, May 2004 pp 304-314
- Y. QUERE, and al «Frequency Domain Analysis of Transmission Zeroes on High-Speed Interconnects in the Presence of an Orthogonal Metal Grid Underlayer» IEEE trans on Advanced Packaging, Vol 31 n°4, Nov 2008, pp: 684-691.
- T. LE GOUGUEC, P.M. MARTIN "Impact by an Orthogonal Metal Grid upon Differential- and Common-Mode Characteristics of Coupled Lines in PCB Technology Structures" 14th IEEE workshop on Signal Propagation on Interconnects May 09-12 2010 Hildesheim Germany.