



**HAL**  
open science

# Frequency-Independent Active Phase Shifters for UWB applications

Blaise Ravelo, Marc Le Roy, André Pérennec

► **To cite this version:**

Blaise Ravelo, Marc Le Roy, André Pérennec. Frequency-Independent Active Phase Shifters for UWB applications. 40th European Microwave Conference, Sep 2010, Paris, France. pp.1774-1777, 10.23919/EUMC.2010.5616703 . hal-00524304

**HAL Id: hal-00524304**

**<https://hal.univ-brest.fr/hal-00524304>**

Submitted on 7 Oct 2010

**HAL** is a multi-disciplinary open access archive for the deposit and dissemination of scientific research documents, whether they are published or not. The documents may come from teaching and research institutions in France or abroad, or from public or private research centers.

L'archive ouverte pluridisciplinaire **HAL**, est destinée au dépôt et à la diffusion de documents scientifiques de niveau recherche, publiés ou non, émanant des établissements d'enseignement et de recherche français ou étrangers, des laboratoires publics ou privés.

# Frequency-Independent Active Phase Shifters for UWB applications

Blaise Ravelo<sup>1</sup>, Marc Le Roy<sup>2</sup> and André Pérennec<sup>2</sup>

<sup>1</sup>*IRSEEM,*

*ESIGELEC, Technopôle du Madrillet, avenue Galilée, BP 10024, 76801, Saint-Etienne du Rouvray Cedex*

<sup>2</sup>*Lab-STICC, UMR CNRS 3192*

*UEB, Université de Brest (UBO), 6 avenue Le Gorgeu, CS93837, 29238 Brest cedex 3*

[Marc.LeRoy@univ-brest.fr](mailto:Marc.LeRoy@univ-brest.fr)

**Abstract**— This paper describes an active phase shifter, which exhibits a frequency-independent phase shift over the ultra-wideband (UWB) frequency range. The design of this pure phase shifter relies on the use of a negative group delay (NGD) circuit. The topology of the active NGD cell is based on a Field Effect Transistor in cascade with a series resonant network. A  $90^\circ \pm 5^\circ$  phase shifter with a single NGD stage was designed, at first, and implemented in hybrid microstrip technology; its measurements showed a 75% relative bandwidth and validated the proposed approach. Then, a compact pure phase shifter with a multi-stage NGD cell was designed. It was aimed at meeting specifications in the UWB frequency range, i.e. 3.1-10.6 GHz (110% relative band). Over this band, the corresponding simulation results showed a constant transmission phase of  $-45^\circ \pm 3^\circ$ , an insertion gain from 2 to 5.5 dB and insertion losses better than 9 dB.

## I. INTRODUCTION

Further to the study by Veselago [1] and those by Smith and Pendry [2]-[3], many authors have investigated, theoretically and by experiments, the properties provided by artificial materials, known as metamaterials. For example, some resonant artificial materials and their equivalent 1-D planar circuits [4]-[5] are able to generate a negative group velocity over a limited frequency band where anomalous dispersion occurs. Generally, these frequency bands are rather narrow and associated with high attenuation values in transmission. Electronic active circuits generating negative group delay (NGD) were proposed in [6]-[7], at first as demonstrators to study this intriguing property, and finally to compensate for losses and to widen the relative operating frequency band. In these electronic circuits, the notion of group delay is preferred to that of group velocity because the circuit length may be undefined in the case of lumped, or integrated, components. Nevertheless, as these circuits use classical electronic components and particularly operational amplifiers, their operating frequency bands are restricted below a few hundreds of MHz [6]-[7]. The idea of a negative group delay synthesizer was validated by Lucyszyn et al. [8], but as the device was operating in reflection, the range of possible applications was restricted by the transmission losses as observed for resonant planar metamaterial circuits.

To overcome these limitations and give the opportunity to apply this “non-commonly-found-in-nature” property, the

authors have proposed in previous studies a new NGD active topology [9]-[11]. It consists in an active microwave circuit that provides a significant NGD value and gain. The topology is based on a Field Effect Transistor (FET) so as to permit operation in different frequency bands or over broad bandwidths according to the type of the chosen FET. As the first realization completely fulfilled these objectives [9], two major application domains were identified: i) the initial microwave topology was converted into a baseband one dedicated to high-speed signals in order to equalize or compensate for interconnect or passive-circuit parasitic effects [10],[12]. ii) In the second domain of applications, i.e. microwave devices, the negative group delay which corresponds to a positive phase slope, was directly used as a basic element to design a pure phase shifter [13]-[14]. A pure phase shifter is a phase shifter with a constant (i.e. frequency-independent) transmission phase; this notion was introduced in 1920 for analogue modulations [15]. More recently, several pure phase shifters were proposed at higher frequency bands [16]-[17]. But their transmission losses were non negligible, or they operated in narrow frequency bands or their implementation was difficult. In [18], an ultra-wideband (UWB) phase shifter easy to implement was described but it presented a constant phase shift between two output accesses and not a constant transmission phase as proposed here. Moreover, this passive distributed circuit proved to exhibit transmission losses.

In this paper, after a brief recall of the NGD active circuit theory, the principle of the proposed frequency-independent phase shifter is detailed in the case of a single NGD cell circuit. The design and implementation of this  $90^\circ$  phase shifter are reported, and the results from simulations and measurements are compared and discussed. Then, to widen the operating bandwidth, a multistage NGD pure phase shifter was designed. The simulations showed a  $-45^\circ$  constant transmission phase over the 3.1-10.6 GHz band with a gain within 2 and 5.5 dB and return losses better than 9dB. The advantages and limitations of this technique are discussed and some improvements are considered.

## II. ACTIVE NGD CELL THEORY

The NGD unit cell, required by the design principle of the proposed phase shifter, simply consists of an RLC series network in cascade with a FET [11].

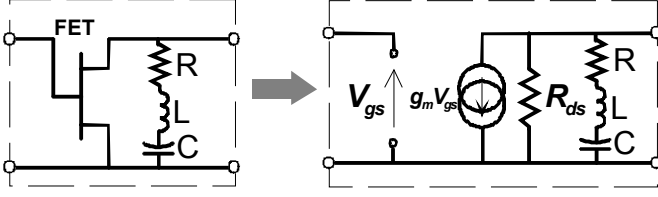

Fig. 1. Unit cell of active NGD circuit and its low frequency model.

In [11], by considering the low frequency model of the FET, i.e. a voltage-controlled current source with a transconductance,  $g_m$ , in cascade with the drain-source resistor,  $R_{ds}$ , simple analytical expressions for the S-parameters of this cell were obtained. Moreover, it was demonstrated theoretically and experimentally that the group delay is always negative at the resonance frequency,  $\omega_0 = 1/\sqrt{LC}$ :

$$\tau_0 = \frac{-2LR_{ds}Z_0}{R[Z_0R_{ds} + Z_0(R + R_{ds})]}, \quad (1)$$

where  $Z_0 = 50 \Omega$  is the reference impedance port. For a given FET, the cell may also generate gain under certain conditions of compromise between  $L$  and  $C$ :

$$|S_{21}(\omega_0)| = \frac{2RZ_0g_mR_{ds}}{[Z_0R_{ds} + R(Z_0 + R_{ds})]} \quad (2)$$

Indeed, by inverting these equations, the network synthesis equations are expressed as:

$$R = \frac{S_{21}R_{ds}Z_0}{2g_mZ_0R_{ds} - (R_{ds} + Z_0)S_{21}}, \quad (2)$$

$$L = -\frac{\tau S_{21}g_m(R_{ds}Z_0)^2}{[2g_mR_{ds}Z_0 - (R_{ds} + Z_0)S_{21}]^2}, \quad (3)$$

where  $S_{21} = |S_{21}(\omega_0)|$  and the group delay  $\tau = \tau(\omega_0)$  are the objectives.  $C$  is simply deduced from the resonance frequency:

$$C = 1/(L\omega_0^2). \quad (4)$$

A series resistor is usually used to match the output access and a parallel one for the input access.

## III. PRINCIPLE AND DESIGN OF FREQUENCY-INDEPENDENT PHASE SHIFTERS

The proposed topology of the frequency-independent phase shifter is depicted in Fig. 2. In fact, a positive group delay

(PGD) circuit, for example a transmission line, is cascaded with a negative group delay circuit. To get a frequency-independent transmission phase, the group delay values of the PGD and the NGD devices must be alike, but of opposite sign. Theoretically, the total group delay is then close to zero. It also corresponds to cascading devices with identical phase slope of opposite signs to achieve an overall constant phase value over a specified frequency band.

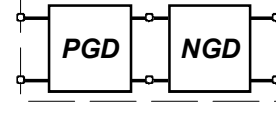

Fig. 2. Bloc diagram of the proposed phase shifter.

### A. Design and Validation of a One Stage 90° Pure Phase Shifter

As proof-of-concept circuit, a one stage phase shifter (PS) [13] was designed by first using the synthesis relations. A single NGD cell presents at its resonance a phase shift close to 180° (Fig. 3) due to the drain-source current direction. Then, to achieve the objective of 90°, the line length is set in a value such that its phase shift is around -90° at this particular frequency.

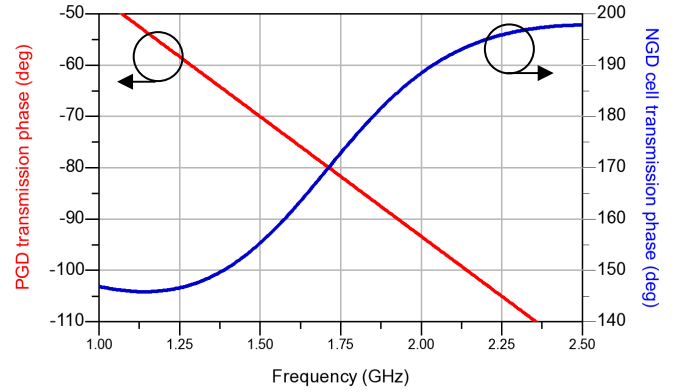

Fig. 3. Transmission phases of the transmission line and of the NGD cell.

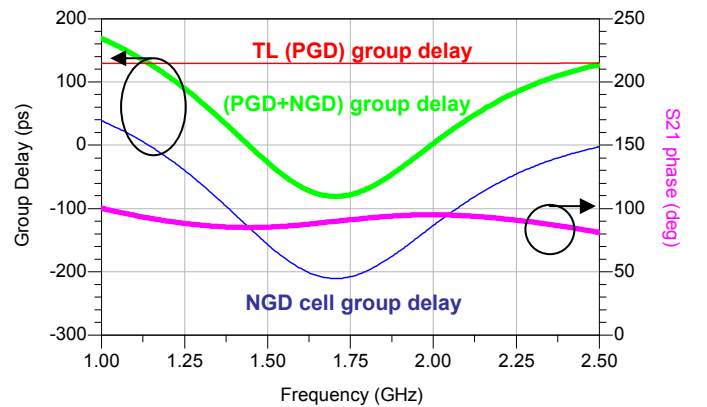

Fig. 4. NGD cell-, transmission line- and both cascaded-group delays; cascaded (PGD+NGD) transmission phase.

Then, the NGD positive phase slope is optimized to get the opposite of the line one over the widest frequency band. Figs. 3 and 4 illustrate this principle: Fig. 3 shows the simulated PGD and NGD transmission phases and Fig. 4 depicts the group delays of the three circuits (PGD, NGD and PGD+NGD) as well as the overall simulated transmission phase. Finally, a final slight optimization under an EM software was performed by taking into account the transistor and the passive component S-parameters. This circuit was implemented in planar microstrip technology and biased by a classical passive network.

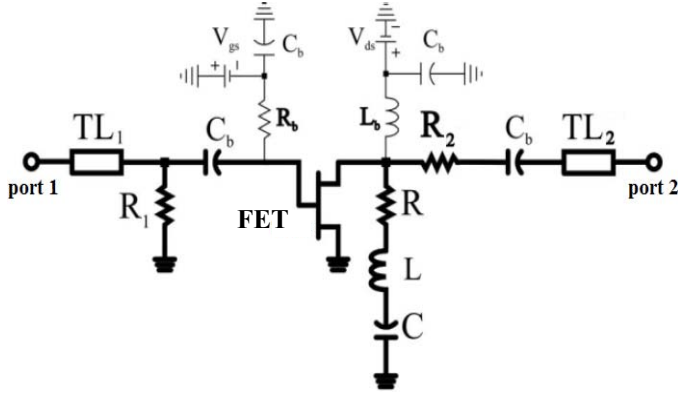

Fig. 5. Detailed schematic of the 90° phase shifter: PHEMT EC2612 FET ( $g_m = 98.14$  mS and  $R_{ds} = 116.8 \Omega$ , bias network in thin lines ( $V_{gs} = -0.1$  V,  $V_{ds} = 3$  V,  $I_{ds} = 30$  mA).  $R_1 = 51 \Omega$ ,  $R_2 = 22 \Omega$ ,  $R = 33 \Omega$ ,  $L = 4.7$  nH,  $C = 1$  pF,  $C_b = 22 \mu\text{F}$ ,  $L_b = 220$  nH,  $R_b = 1$  k $\Omega$ . Transmission lines, TL:  $w = 952 \mu\text{m}$  and  $d = 6.2$  mm.

Figs. 6 and 7 compared simulation (run under Momentum software) and experimental results. They show that the agreement is globally satisfying. The measured group delay and constant phase show frequency characteristics widened by comparison to simulation results. It is worth noting that the measured gain is slightly lower than to the simulated one. The measured gain is kept within -2 and 2 dB. The measured phase is  $90^\circ \pm 5^\circ$  from 1.08 GHz to 2.42 GHz, which corresponds to a 76.5% relative band and the return losses are better than 10 dB over this band.

Moreover, the total group delay is effectively close to zero and the active phase shifter has a compact size of 2 cm by 2.3 cm.

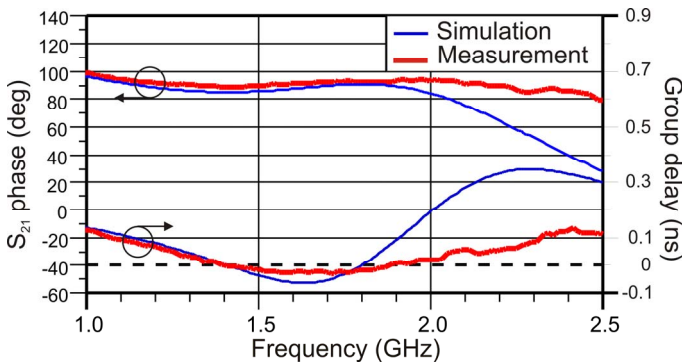

Fig. 6. Transmission phase and group delay values obtained by simulations and measurements.

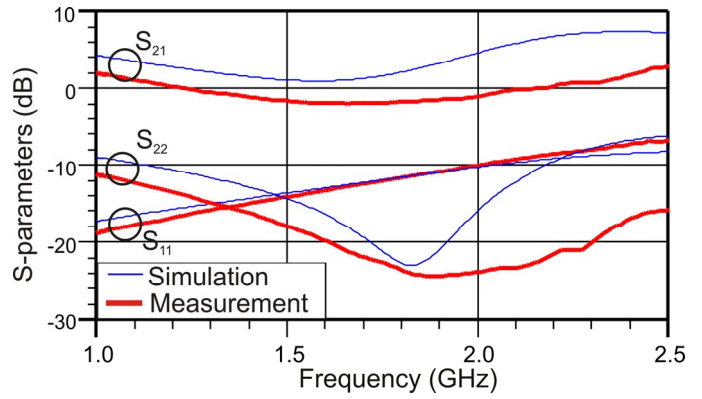

Fig. 7. Simulated and measured  $S_{21}$ -magnitude and return losses.

### B. Design and Simulations of a -45° UWB Pure Phase Shifter using Multistage of NGD Cells

Further to this proof-of-concept validation, a -45° phase shifter was designed by using the same approach as the one detailed in [9] to widen the operating frequency band. As put forward in [13], it is advised to use an even number of FETs to get phase values between 0 and -180°. Then, three different resonant cells and two EC-2612 PHEMT FETs were used to get -45° with gain for UWB applications, i.e. for a frequency band extending from 3.1 to 10.6 GHz. Each cell was designed according to both the synthesis equations and the previously detailed process. Then, a final optimization was performed by taking into account the FET S-parameters. Fig.8 shows the ADS schematic. The group delay and the transmission phase are both plotted in Fig. 9, whereas the S-parameter magnitudes are presented in Fig. 10.

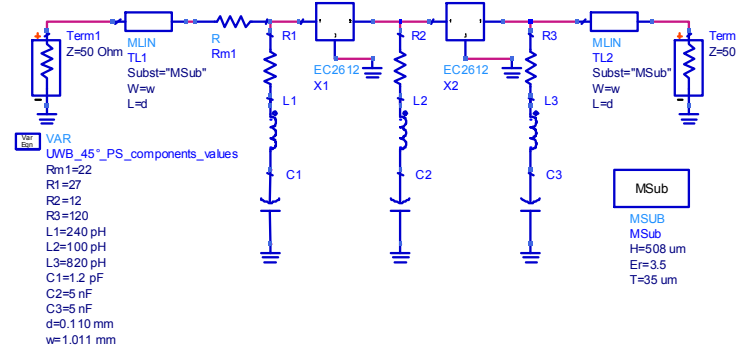

Fig. 8. ADS schematic of the UWB phase shifter with the component values and the substrate characteristics.

One should note that, in the UWB, the gain lies within 2 and 5.5 dB, and the return losses are better than 9 dB, the  $S_{21}$ -phase is close to -45° with a variation from -41° to -47°. Once again, it is worth underlining that the device is of compact size. The whole group delay is close to zero, and even slightly negative from 3.1 to 7.4 GHz. Due to the FET non-reciprocity, the PS also presents a high isolation value, which may be an advantage depending on the final application.

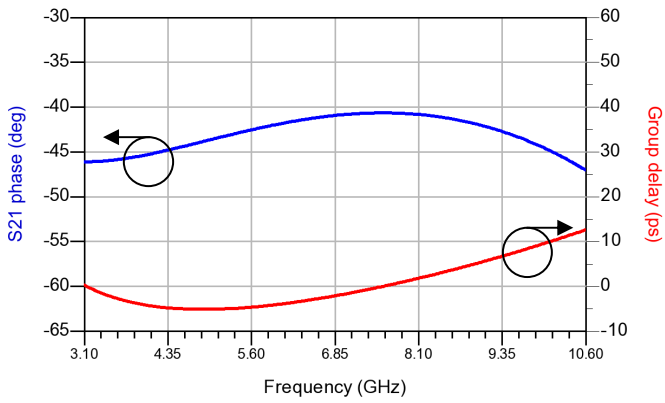

Fig. 9. Transmission phase and group delay of the  $-45^\circ$  UWB phase shifter.

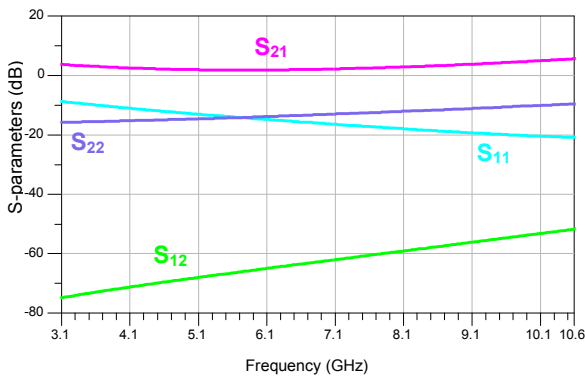

Fig. 10. Simulated S-parameters.

Using lumped components in simulations up to 10.6 GHz may seem inconsistent with a hybrid implementation, particularly for inductances. Nevertheless, chip thin film inductors, operating up to these frequencies, are now available and an MMIC integration is also possible.

#### IV. CONCLUSIONS

Design examples of pure phase shifters were presented. To get a frequency-independent transmission phase, two devices were cascaded with identical absolute phase slopes but of opposite signs. In theory, this means that the cascaded elements have opposite constant group delay value; this results in a total group delay close to zero. This kind of phase shifter should be distinguished from most of the available phase shifters: here, the transmission phase is constant but not the phase shift between two branches as in classical phase shifters. To provide a positive phase slope, a negative group delay circuit is needed. The authors proposed an NGD topology able to provide gain and NGD, and used this circuit to implement a  $90^\circ$  frequency-independent phase shifter in hybrid technology. The experimental results validated the principle of design and the synthesis relations. Indeed, this single-NGD-stage showed a  $90^\circ \pm 5^\circ$  transmission phase over a 75% relative bandwidth centred around 1.75 GHz, with a gain between -2 and 2 dB. Then, multi-stage NGD cells were used to design a  $-45^\circ$  UWB pure phase shifter in order to widen the

operating bandwidth. The simulation results confirm a  $-45^\circ \pm 3^\circ$  transmission phase from 3.1 to 10.6 GHz with a gain within 2 and 5.5 dB. EM simulations of this latter circuit are in progress and its implementation is planned. Ongoing researches are focused on the design of tunable pure PSs.

#### REFERENCES

- [1] V. Veselago, "The electrodynamics of substances with simultaneously values of  $\epsilon$  and  $\mu$ ", *Soviet Physics Uspekhi*, vol. 10, no. 4, pp. 509-514, 1968.
- [2] J. B. Pendry, "Negative Refraction Make a Perfect Lens", *Phys. Rev. Lett.* 85, 3966, 2000.
- [3] R. A. Shelby D. R. Smith and S. Schultz, "Experimental verification of a negative index of refraction", *Science*, vol. 292, no. 5514, pp. 77-79, Ap. 2001.
- [4] George V. Eleftheriades, Omar Siddiqui, and Ashwin K. Iyer, "Transmission Line for Negative Index Media and Associated Implementations Without Excess Resonators", in *IEEE MWC Lett.*, vol. 13, N° 2, 51, February 2003.
- [5] A. Lai, C. Caloz, and Itoh, "Composite Right/Left-Handed transmission Line Metamaterials", *IEEE Microwave Magazine*, vol. 5, pp. 34-50, Sept. 2004.
- [6] D. Solli, R. Y. Chiao, "Superluminal effects and Negative delays in Electronics and their Applications", *Physical Review E*, Issue 5, Nov. 2002.
- [7] M. Kitano, T. Nakanishi, K. Sugiyama, "Negative Group Delay and Superluminal Propagation: An electronic circuit Approach", *IEEE Journal of selected Topics in Quantum*.
- [8] S. Lucyszyn, I. D. Robertson, and A. H. Aghvami, "Negative group delay synthesiser", *Electron. Lett.*, Vol. 29, 1993, pp. 798-800.
- [9] B. Ravelo, A. Pérennec, and M. Le Roy, "Synthesis of broadband Negative Group Delay Active Circuits", *IEEE MTT-S Symp. Dig.*, Honolulu (Hawaii), 2-9 June 2007, pp. 2177-2180.
- [10] B. Ravelo, A. Pérennec, and M. Le Roy, "Negative group delay active topologies respectively dedicated to microwave frequencies and baseband signals", *Journal of EuMA*, Vol. 4, Jun. 2008, pp. 124-130.
- [11] B. Ravelo, A. Pérennec, M. Le Roy, and Y. Boucher, "Active microwave circuit with negative group delay", *IEEE MWC Lett.*, vol. 17, Issue 12, Dec. 2007, pp. 861-863.
- [12] B. Ravelo, A. Pérennec, and M. Le Roy, "Application of negative group delay active circuits to reduce the 50% propagation Delay of RC-line model", 12th IEEE Workshop on Signal Propagation on Interconnects, Avignon, France, May 2008.
- [13] B. Ravelo, M. Le Roy, and A. Pérennec, "Application of negative group delay active circuits to the design of broadband and constant phase shifters", *Microwave and Opt. Tech. Lett.*, vol. 50, n°12, Dec. 2008, pp. 3077-3080.
- [14] B. Ravelo, A. Pérennec, M. Le Roy, "Broadband Balun Using Active Negative Group Delay Circuit", 37th European Microwave Conference, Munich, Oct. 2007.
- [15] R. V. L. Hartley, U.S. Patent 1 666 206, 1928.
- [16] J. J. H. Wang, J. K. Tillery, G. T. Thompson, K. E. Bohannon, R. M. Najafabadi and M. A. Acre, "A Multioctave-Band Photonicly-Controlled, Low-Profile, Structurally-Embedded Phased Array with Integrated Frequency Independent Phase-Shifter", *IEEE International Symposium on Phased Array Systems and Technology*, Boston, MA, pp. 68-73, Oct. 15-18, 1996.
- [17] Y. J. Ko, J. Y. Park and J. U. Bu, "Integrated RF MEMS Phase Shifters with Constant Phase Shift", *IEEE MTT-S Symp.*, Philadelphia, pp. 1489-1492, June 2003.
- [18] A. M. Abbosh, "Ultra-Wideband Phase Shifters", *IEEE Trans. MTT*, Vol. 55, No. 9, pp. 1935-1941, Sep. 2007.