



HAL
open science

Study of Proximity-Coupling: Application to new RF-Interconnects

Yves Constant Mombo Boussougou, Thierry Le Gouguec, Yves Quéré, Fabrice Huret

► **To cite this version:**

Yves Constant Mombo Boussougou, Thierry Le Gouguec, Yves Quéré, Fabrice Huret. Study of Proximity-Coupling: Application to new RF-Interconnects. 6th Conference IEEE on Ph.D. Research in Microelectronics & Electronics, Jul 2010, Berlin, Germany. hal-00516022

HAL Id: hal-00516022

<https://hal.univ-brest.fr/hal-00516022>

Submitted on 8 Sep 2010

HAL is a multi-disciplinary open access archive for the deposit and dissemination of scientific research documents, whether they are published or not. The documents may come from teaching and research institutions in France or abroad, or from public or private research centers.

L'archive ouverte pluridisciplinaire **HAL**, est destinée au dépôt et à la diffusion de documents scientifiques de niveau recherche, publiés ou non, émanant des établissements d'enseignement et de recherche français ou étrangers, des laboratoires publics ou privés.

Study of Proximity-Coupling: Application to new RF-Interconnects

Y. C. Mombo Boussougou, T. Le Gouguec, Y. Quéré, F. Huret

Université Européenne de Bretagne, France
Université de Brest ; CNRS, UMR 3192 Lab-STICC, ISSTB,
6 avenue Victor Le Gorgeu, CS 93837, 29238 Brest cedex 3, France
e-mail: constant.mombo@univ-brest.fr

Abstract — The new concept of RF Interconnect presented in this paper is aimed at replacing conventional interconnections in digital circuits. The study was, thus, focused on the transmission channel composed of contactless transitions. After a brief recall of the theory, an RF interconnection was modeled through use of multiplexing digital CDMA and amplitude modulation and characterized by using a co-simulation tool. The signal forms observed along the transmission system and the frequency response of the RF channel are presented to highlight the capabilities of this RF interconnect.

Keywords-radiofrequency; coupling; contactless interconnect; modulation; multiplexing; capacitive.

I. INTRODUCTION

The performances of integrated circuits such as Systems on Chip (SoC), Systems in Package (SiP) or Systems on Package (SoP) are limited by the global interconnect layers. Indeed, the increase in the number of circuit features, despite the progress in terms of integration, leads to an increase of chip surface at the origin of a lengthening of global interconnects, which extends the delays in information transmission. To reduce these effects, new solutions for signal transmissions need to be developed. Among the solutions under consideration let us cite optical interconnects, 3D interconnects and radio frequency (RF) interconnects [1-4]. Optical interconnects allow important flows, but require a significant change in the chip-making technology, which implies a high implementation cost. By taking advantage of functional block superposition, 3D-interconnects allow reduction of line lengths. However, arranging such optimal system architectures may be very difficult or even impossible, and several long interconnects may still exist. There are two kinds of RF interconnects corresponding to the transport of information either by radio, or by a waveguide used as a transmission medium. But, the interest of using radio signals to distribute clock ones is decreased by the problems of electromagnetic compatibility (EMC) and the size of antennas.

Together these considerations led us to carry out an electromagnetic study of RF interconnects, i.e. microstrip or coplanar lines, compatible with the current microelectronic technologies.

Section II presents the concept of RF interconnects and its possible applications in the transmission of many binary

signals. Then, Section III deals with the study and the modeling of different couplings aimed at realizing a contactless transmission to the microwave line. Finally, an example of digital/analog co-simulation for the characterization of RF-interconnections is given in Section IV. Our conclusions are drawn in Section V, and clues are given about the perspectives opened by this study.

II. RF-INTERCONNECT CONCEPT

RF interconnects can be used for the distribution of clock signals or to replace parallel data buses [5-6]. In this paper, Fig.1 illustrates the principle of RF interconnect in the case where it replaces a classical 16-bit bus (Fig. 1). With such a parallel bus at 100 Mbits/s, information is transmitted at $16 \times 100 \text{ Mbits/s} = 1.6 \text{ Gbits/s}$. But, the coupling between the signal lines makes difficult any increase of the speed. To be equivalent to the parallel 16-bit bus, the proposed serial interconnect (Fig. 2) must authorize a similar data rate (1.6 bits/s). By transmitting all bits simultaneously with a proper multiplexing technique, an RF-interconnect (Fig. 3) allows one to overcome the slowness of baseband transmission and to reduce the number of lines.

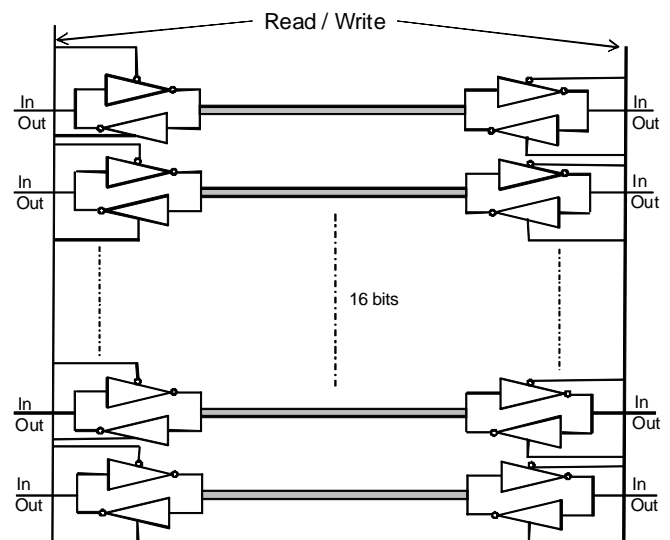

Fig. 1. Classical 16-bit bus interconnect

To transmit signals to the RF-line many solutions are available, but here focus is on contactless transitions. Indeed, the low-frequency noise generated by digital circuits is filtered by using a contactless coupling between the digital circuits and the RF-line filters. Moreover, this is relevant in terms of achievement of reconfigurable circuits. The characteristics of a contactless coupling make that the digital signals have to be modulated for transmission via the microwave channel. In addition, because of the simultaneous transmission of the multiple signals, the use of multiplexing techniques such Frequency Division Multiple Access (FDMA) or Code Division Multiple Access (CDMA) is necessary.

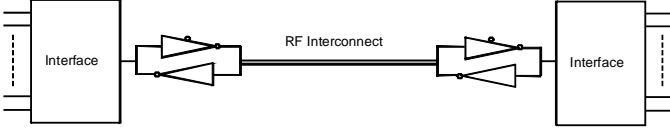

Fig. 2. Serial transmission

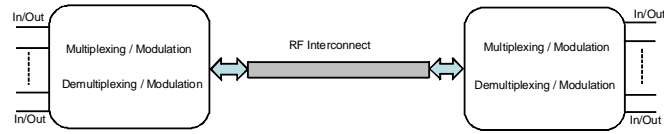

Fig. 3. 16-bit RF interconnect with CDMA

The next section will be devoted to the study of contactless coupling between two lines

III. CONTACTLESS TRANSITION BETWEEN TWO LINES

A. Capacitive Coupling

The replacement of metallic vias by a coupling contactless access to the RF interconnect would limit the baseband noise and enhance flexibility.

Let us study, at first, the case of a coupling through capacity as shown in Fig. 4. a. The associated equivalent circuit model is presented in Fig. 4. b.

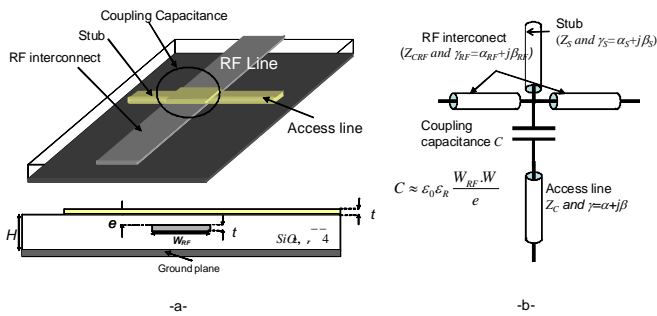

Fig. 4. Coupling capacitance between two microstrip lines (a), equivalent circuit model (b)

As a first approximation, the value of the coupling capacitance can be determined by the planar capacitance as follows:

$$C \approx \epsilon_0 \epsilon_R \frac{W_{RF} \cdot W}{e} \quad (1)$$

where W_{RF} is the width of the RF interconnect line, W is the width of the access line, e is the gap between the two lines,

and ϵ_R is the relative permittivity of the substrate between the two lines. More accurate expressions of the capacitance are available in [7].

One of the simplest contactless couplings is a capacitive coupling between the digital and the RF line.

To determine the parameters that have a great influence on the transmission level, let us calculate the transfer function of a radiofrequency interconnect. The corresponding scheme is presented in Fig. 5; one should note that it is more complete than the one presented by Sun *et al.* [8] because of the addition of stubs with their loads to the sections of interconnects corresponding to ports. The stubs can be used to optimize both the transmission gain and the bandwidth, or to allow the simulation of another charge on the line.

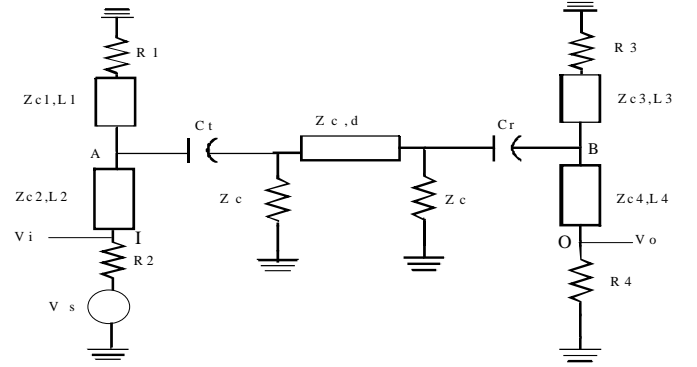

Fig. 5. Electric circuit for the transfer function calculation

For greater clarity the transfer function calculated here corresponds to the power gain of the structure depicted in Fig. 5 when the lengths, L_2 and L_4 , are both neglected. It represents the output-to-input power ratio expressed as follows:

$$H(\omega) = \frac{P_o}{P_i} \quad (2)$$

$$H(\omega) = \frac{Z_P}{R_4} \left(\frac{Z_{R3} // R_4}{Z_{C_r} + Z_{R3} // R_4} \right)^2 \left(\frac{Z_{in} // Z_C}{Z_{C_t} + Z_{in} // Z_C} \right)^2 \times \left(\cosh(\gamma d) - \frac{Z_C}{Z_{in}} \sinh(\gamma d) \right)^2 \quad (3)$$

$$\text{where } Z_{in} = Z_C \frac{Z_L + Z_C \tanh(\gamma d)}{Z_C + Z_L \tanh(\gamma d)} \quad (4)$$

$$Z_L = (Z_{R3} // R_4 + Z_{C_r}) // Z_C \quad (5)$$

$$Z_P = (Z_{in} // Z_C + Z_{C_t}) // Z_{R1} \quad (6)$$

Z_{R1} and Z_{R3} are, respectively, the equivalent impedances of stubs 1 and 3.

This transfer function permits the assessment of the influence exerted by various parameters such as the coupling capacitance, C_T or C_R , the characteristic impedance of the RF line, Z_C , and the access impedances, R_2 and R_4 . For example, Fig. 6 illustrates the evolution of the power gain for several values of coupling capacitance in the case where

$C_T = C_R = C_C$. As expected, it shows that the higher the capacitance value is, the higher the level of transmission is. So, the use of high coupling capacitances will necessitate a rather large surface area and a small gap between both levels.

At this stage, it is worth wondering about the impact of the characteristic impedance of the RF interconnect on transmission. It is illustrated by Fig. 7, where the energy transfer is maximized through use of high-impedance lines. However, in the case of a microstrip RF line of high impedance, its narrow width will lead to significant metal losses. It is, thus, paramount to find a compromise between the characteristic impedance values and metal losses.

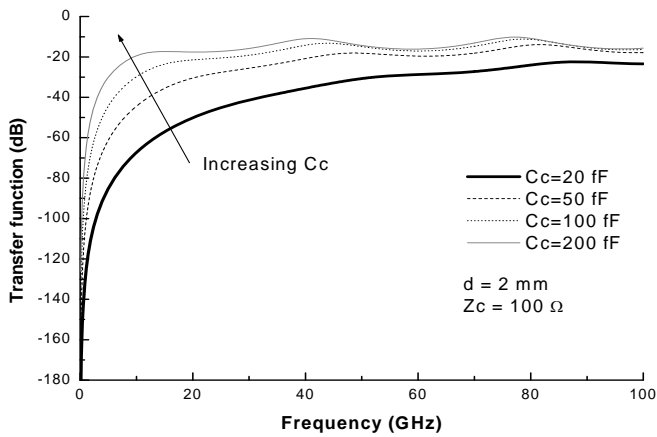

Fig. 6. Frequency variations of the transfer function for different values of the coupling capacitance, C_C

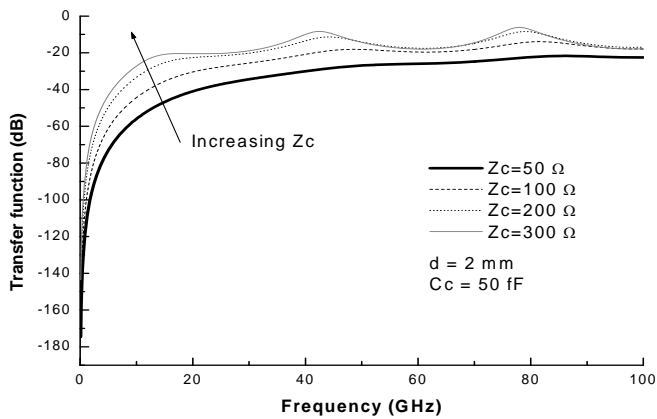

Fig. 7. Frequency variations of the transfer function for different values of the characteristic impedance, Z_C

This study was conducted by considering the capacitive coupling between microstrip lines and/or coplanar waveguide. However, the availability of a large variety of microwave transmission lines can also allow the development of other forms of coupling.

The plots of variations of the transfer function versus the coupling capacitance show that high capacitance values are needed to enhance the transmission. But, according to technological considerations, this is uneasy. It is thus necessary to consider other solutions.

B. Microstrip line and slotline coupling

According to the investigations reported in [9] about the coupling between a microstrip line and a slotline, a broadband transmission is possible with high transmission levels.

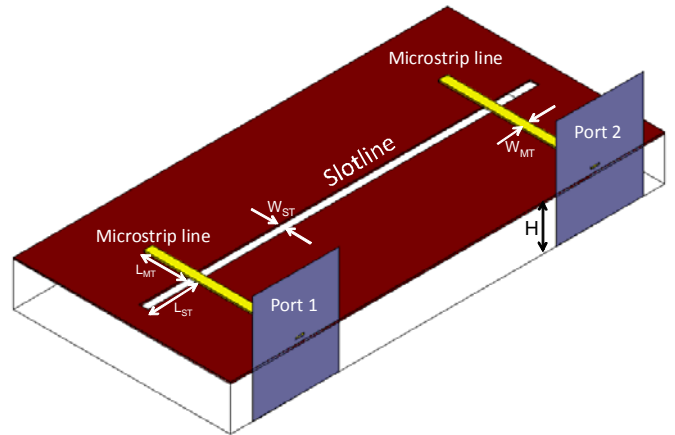

Fig. 8. 3D structure of a microstripline-slotline transition

Figure 8 shows the 3D structure of a microstripline-slotline transition for a 2-port communication. Using the circuit model presented in Fig. 8, the impedances and stubs lengths structure can be optimized. Simulations run with optimized parameters, i.e. $L_{MT} = 552 \mu\text{m}$, $L_{ST} = 522 \mu\text{m}$, $Z_{MT} = 174 \text{ Ohms}$ and $Z_{ST} = 411 \text{ Ohms}$, led to the optimized S-parameters curves presented in Fig. 9.

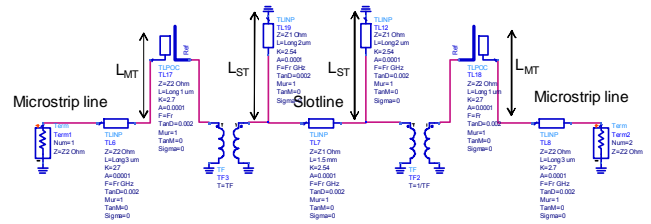

Fig. 9. Circuit model of a microstripline-slotline transition.

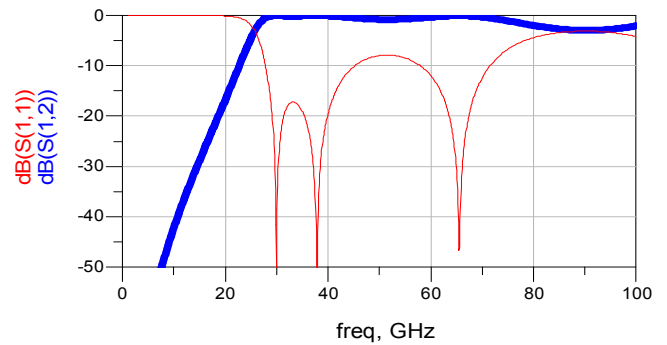

Fig. 10. S-parameters of a microstripline-slotline transition

One should note that the device behaves like a high-pass function. Its frequency response is relatively flat and the losses induced by the double transition are low over a band from 30 to 70 GHz.

IV. CO-SIMULATION FOR RF INTERCONNECT CHARACTERIZATION

A co-simulation tool was used to test different transmission channels and assess the complexity of circuits to be implemented for the realization of RF interconnects.

The principle of the transmission system is illustrated in Fig. 11: the signals are encoded by specific orthogonal codes, and then they are multiplexed and modulated on a high-frequency carrier because of the high pass channel. The information is retrieved through the reverse operation.

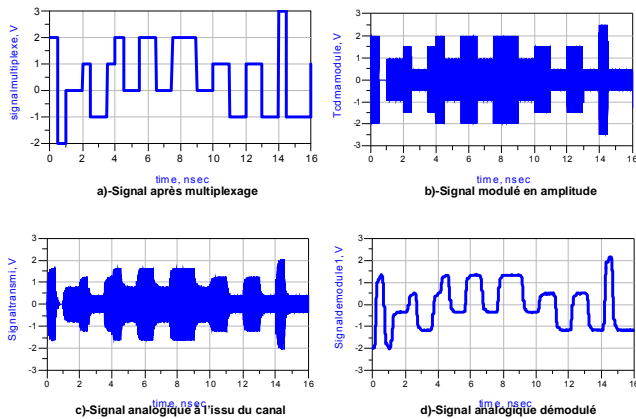

Fig. 11. Various signal forms along the transmission system

Figure 12 illustrates various signal forms along the transmission system before and after the channel. With the co-simulation the digital and analog parts can coexist, and the information transfer is possible under certain constraints for the channel.

V. CONCLUSION

This study demonstrated the feasibility of the concept of RF interconnects through circuit and electromagnetic simulations. Then, we developed the expression of the transfer function so as to determine the parameters to be optimized. It highlighted not only the key-role of the capacitance value, but also the impact of the characteristic impedance value of the RF line.

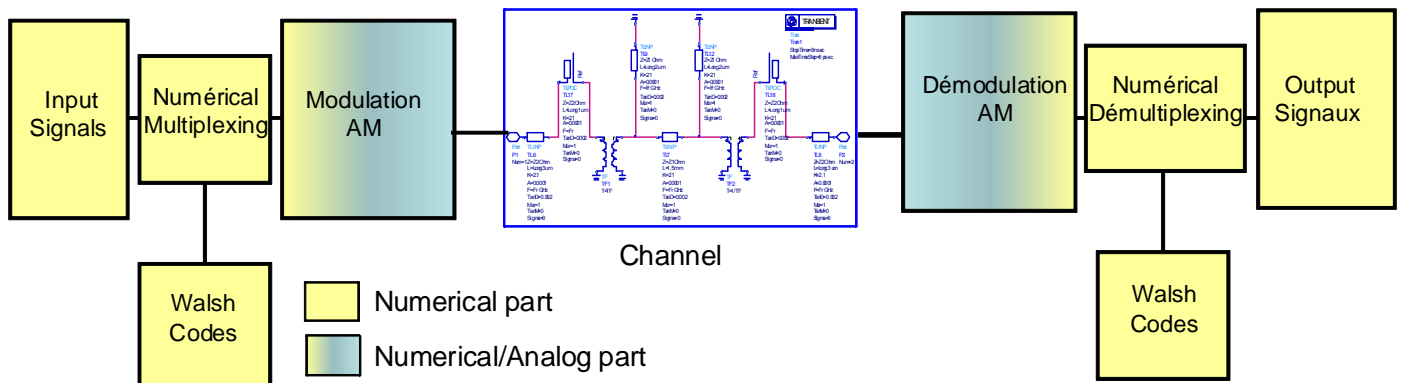

Fig. 11. Diagram of a CDMA transmission system with ASK modulation

At first, our investigations were focused on microstripline-microstripline transitions. Simulations of such a transition provided good values for the S-parameters. The use of this channel in a co-simulation tool enabled us to plot the signals before and after the channel.

There is no doubt that a more detailed study of the technological possibilities and constraints is worth being carried out. A more accurate assessment of such interconnects requires to gain more insight into the complexity of the electronic functions in emission and reception.

REFERENCES

- [1] International Technology Roadmap for Semiconductors (ITRS) 2005-2007.
- [2] Ron Ho, Kenneth W. Mai, Mark A. Horowitz, "The Future of Wires," *Proc. of the IEEE*, vol. 89, pp. 490-504, no.4, April 2001.
- [3] J. A. Davis *et al.*, "Interconnect limits on gigascale integration (GSI) in the 21st century," *Proc. of the IEEE*, vol. 89, pp. 305-324, March 2001.
- [4] Robert H. Havemann, James A. Hutchby, "High-Performance Interconnects: An Integration Overview", *Proceedings of the IEEE*, vol. 89, no. 5, May 2001.
- [5] Woonghwan RyuJunwoo *et al.*, "RF Interconnect for Multi-Gbit/s Board-Level Clock Distribution," *IEEE Trans. on Advanced Packaging*, vol. 23, pp. 398-407, no. 3, August 2000.
- [6] Mau-Chung, Frank Chang *et al.*, "Advanced RF/Baseband Interconnect Schemes for Inter- and Intra-ULSI Communications," *IEEE Trans. electron devices*, vol. 52, pp. 1271-1285, no. 7, July 2005.
- [7] S.-C. Wong *et al.*, "An empirical three-dimensional crossover capacitance model for multilevel interconnect VLSI circuits," *IEEE Trans. Semicond. Manuf.*, vol. 13, no. 2, pp. 219-227, May 2000
- [8] M. Sun, Y. P. Zhang, "Performance of inter-chip RF-Interconnect using CPW, capacitive coupler, and UWB Transceiver," *IEEE Trans. Microwave theory and tech.*, vol. 53, no. 9, September 2005.
- [9] K. C. Gupta *et al.*, "Microstrip Lines et Slotlines", Second Edition.